

Mixed feedback drive circuits for audio output transformers

Using mixed feedback drive circuits with audio output transformers have two major advantages:

1. Transformer-caused distortion is reduced (or almost eliminated)
2. The primary copper resistance of the transformer is eliminated, thus reducing the output impedance correspondingly.

The circuits below illustrate the principles for mixed feedback. In real applications, additional components may have to be added to reach desired performance.

NOTE! Application of mixed feedback principles for audio output was covered by a German patent DE 29 01 567 with application day 13.1.79. As far as we understand, the patent has now expired.

Unbalanced drive

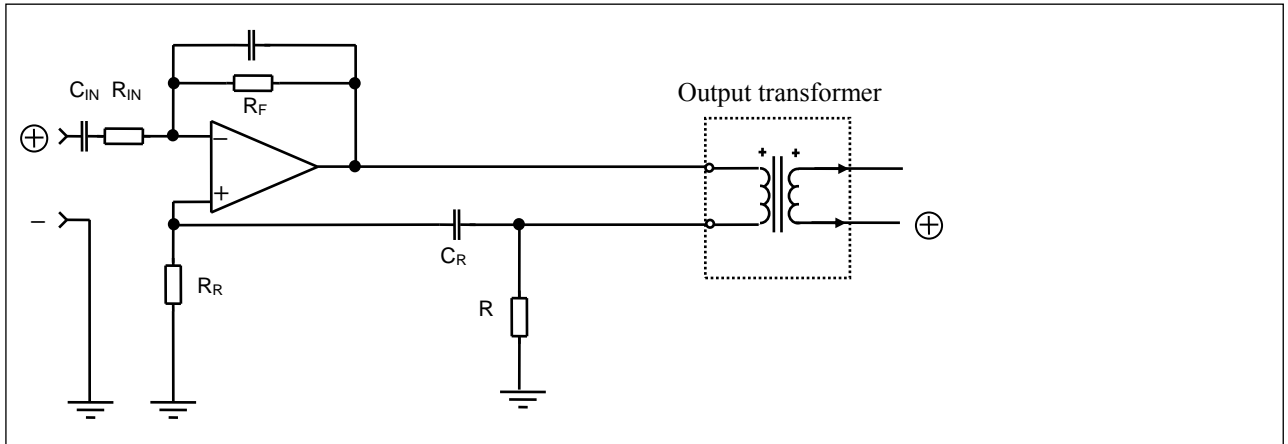

Gain = $R_F / R_{IN} \cdot$ Transformer turns ratio.

Select $R_R \sim R_{IN}$

Select C_R such that $1 / (2\pi \cdot R_R \cdot C_R) \ll F_{MIN}$, the lowest desired output frequency.

Optimum $R = R_{primary} \cdot (R_{IN}/R_F)$, where $R_{primary}$ is copper resistance of primary winding(s).

Select R for good THD at LF, and for good square wave response

Balanced drive

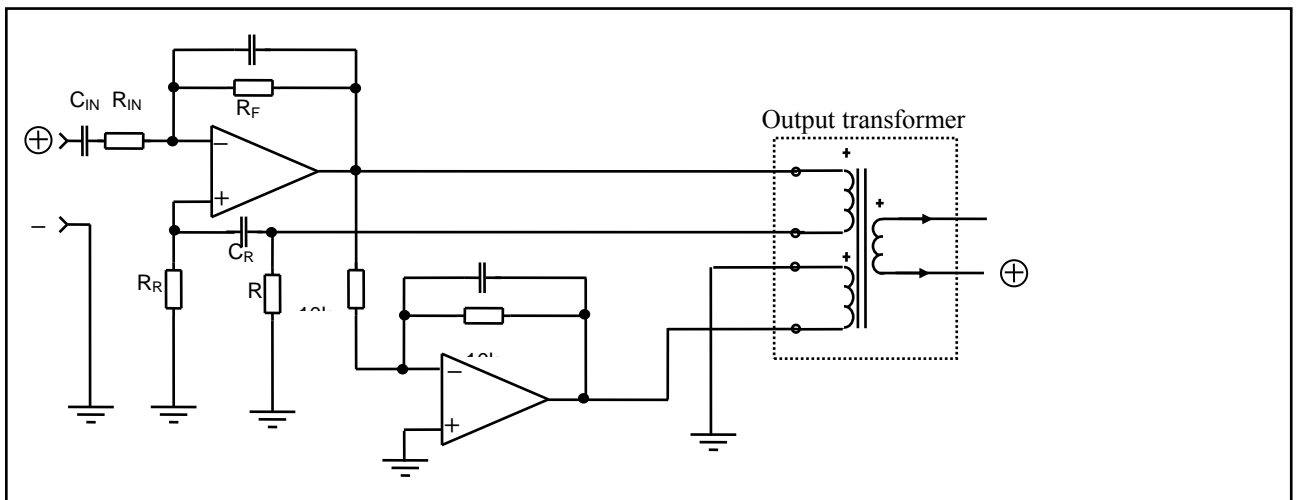

Gain = $2 \cdot R_F / R_{IN} \cdot$ Transformer turns ratio.

Select $R_R \sim R_{IN}$

Select C_R such that $1 / (2\pi \cdot R_R \cdot C_R) \ll F_{MIN}$, the lowest desired output frequency.

Optimum $R \leq R_{primary} \cdot (R_{IN}/R_F) / 2$, where $R_{primary}$ is copper resistance of primary winding(s).

Select R for good THD at LF, and for good square wave response.