

TALK

SOUND

FROM THE MAKERS OF "SCOTCH" BRAND MAGNETIC TAPE

SOUND TALK BULLETIN
NUMBER 40

TAPE CONSIDERATIONS FOR CONTINUOUS LOOP RECORDING

The primary difference between reel-to-reel recording transports and continuous loop transports is the method of supply and takeup of the tape reservoir. Other differences are the conditions of tape tension, head-to-tape contact, transport design and tape construction necessary to best serve this initial difference.

Continuous loop operation refers to any tape transport which provides a method for tape to maintain continuous uninterrupted playing or recording cycles, first by permitting splicing of the tape lead-end to tail-end, and second, by providing a way to collect the temporarily unused portion of that tape loop into a compact mass, commonly called the slack loop, to logically facilitate uninterrupted recycling.

That portion of the tape mass extending from the slack loop to the head assembly and capstan then returning to the slack loop, is generally termed the operating loop. The continuous length of tape, while passing the record or playback heads at a constant speed, is subjected to two notably different tensions between the innermost (supply) circumference of the slack loop and the outermost (takeup) circumference; resulting from the difference in angular velocity of the two.

A typical inner circumference, for example, might be approximately six linear inches of tape, and the outer circumference, 18 inches. Consequently, for each six-inch length drawn from the inner circumference during each revolution of the loop, a shortage of 12 inches of tape develops at the outer circumference. This shortage manifests itself as increased tension at the outer layer; which then adjusts layer-to-layer through the entire slack loop, pulling each inwardly adjacent layer backward in proportionally smaller amounts. It can be seen that the smaller the ratio between the two circumferences, the lower will be the tension at the outer circumference, and the lesser the amount of slippage which must occur between layers.

It can also be seen that the much greater friction developed in the slack loop (versus conventional reel-to-reel operation) dictates that tapes for continuous loop applications be constructed (1) to withstand the excessive friction by utilizing an oxide coating construction with maximum resistance to ruboff, and (2) to counteract potential friction through use of special external dry lubrication on the tape (the construction of which is explained later in this paper) to minimize mechanical resistance.

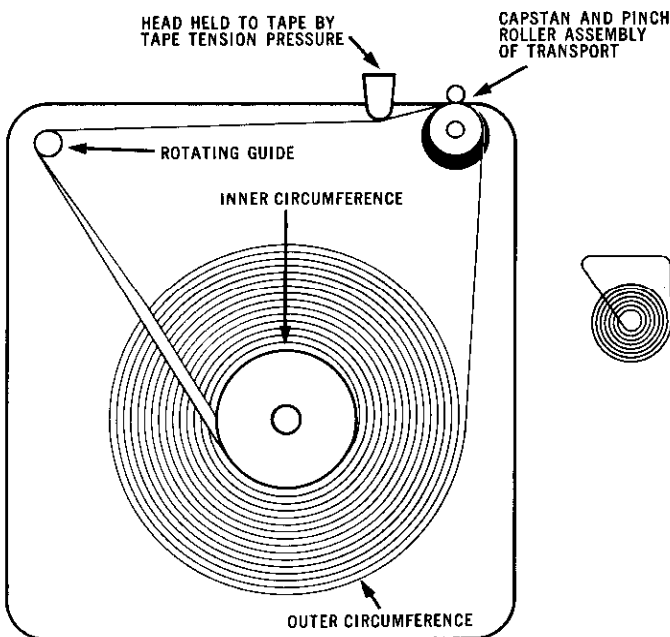

CONTINUOUS LOOP TAPE CARTRIDGE

Magnetic Products Division **3M** COMPANY

"SCOTCH" is a registered trademark of the 3M Co., St. Paul 19, Minn.

To minimize the frictional forces developed within them, transports and modular tape-loop cartridges for this process must be designed to reduce the number and size of areas at which the tape contacts non-moving parts: guides should be of small radius and acute tape-path angles avoided. Design of these components, primarily the inclusion of large diameter hubs, also attempts to minimize the ratio between the inner and outer circumferences. When the inner circumference is near the size of the outer circumference, the tension is relatively small, requiring less layer-to-layer "adjustment" previously described.

It can be noted that to increase tape length capacity of a cartridge, it is best to increase the size of the inner circumference. If additional length were simply added to the outer circumference without enlarging the inner circumference, the tensions explained earlier would greatly increase. By employing a larger inner circumference, the ratio between the two circumferences would not change as greatly, hence tensions would not increase as much.

The amount of friction in a slack loop and in the magnetic tape used can be determined by measuring the tension at the *operating loop* (that length of tape extending from the inner circumference, across the head and capstan assembly and back to the outer circumference).

Such tension is measured by specialized tension gauges, some commercially available, which employ either variable resistors or oscillators mechanically linked to a network of roller guides. Variations in tension cause a "sliding" guide to vary in distance from stationary guides on each side of it, resulting in either a voltage or frequency variation. These variations are read on a meter calibrated in ounces. When readings are taken at the same point in the operating loop (same distance from the capstan assembly), different loops and tape lubrications can be compared for amounts and uniformity of tension.

While perhaps less accurate than commercial tension meters, a simply constructed tension gauge, shown below, will provide practical tension measurement comparisons:

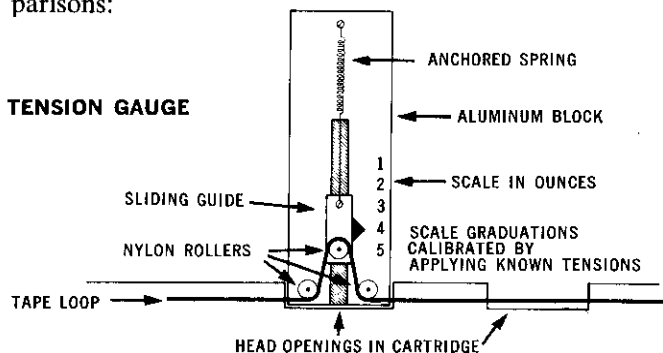

In construction, remember that the spring should extend sufficiently between tensions of 1/2 to 5 ounces to permit spacing the graduations and to permit serving all sizes

of cartridges. To calibrate, hold one end of tape and thread the remainder around the nylon rollers. By then applying standard weights or known spring tensions to the tape, deflections can be noted and indicated on the block opposite the sliding index.

Such equipment is helpful in determining the most efficient slack loop circumferences for smooth tape motion (thus aiding longest slack loop life), and in determining which tape lubricant coatings offer the least mechanical resistance for longest life.

It has been noted, for example, that slack loop tension tests in which the parameters of tape length, transport design, tape speed and loop circumferences remained constant, tape constructions outwardly appearing similar can have tension differentials as high as 50%. In this connection, such factors as the degree of smoothness in the magnetic coating and the type of lubricating coating employed, combine to produce significantly different tension readings. Slack loop size is in part dependent on a critical balance of these two opposing elements in a tape construction.

Higher than desired tensions within a cartridge cause tape to slip at the capstan and pressure (pinch) roller resulting in tape frequency modulation commonly called wow and flutter. Wow and flutter are also evident if too much lubricant is used to overcome that tension—again appearing as capstan/pinch roller slippage.

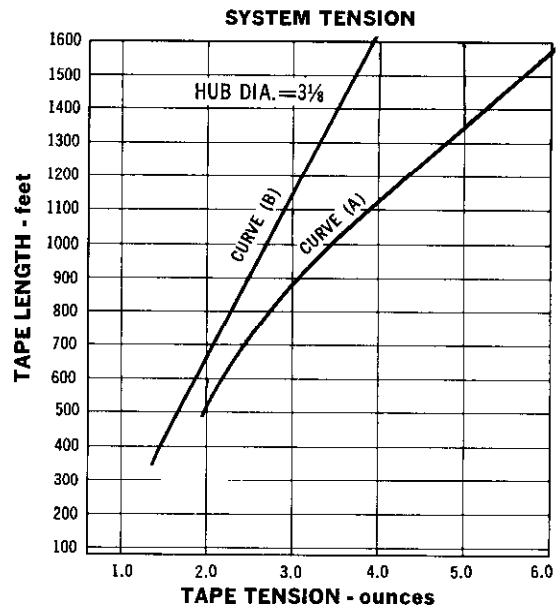

Tape length vs. operating loop tension for two constructions of single-coat lubricated tapes. Tapes cartridge mounted.

Curve "A" reflects tension of standard single-coat tape. Curve "B", newer construction with improved mechanical properties. Efficiency is indicated in curve's approach to vertical, showing greater tape lengths with lesser evidence of friction.

There are two basic constructions of magnetic tape for continuous loop use: a single-coated tape for one-side loops, in which only one surface of the tape is employed in the completion of one playing cycle, and a double-coated tape for mobius loop use, in which twisting the

tape a half-turn at the head-to-tail splice permits recording and playing back both tape surfaces successively in the completion of one cycle.

The above suggests that mobius loop operation would afford twice as much record or playing time in one cycle for a given slack loop size than would the one-side loop. But due to inherent losses at (especially) short wavelengths through poor head-to-tape contact, and to the over-all caliper of double-coated tapes, longer loop cycle time is in fact more qualitatively attainable with one-side loop applications.

MAGNETIC COATINGS

While many lubricated tapes employ oxide formulations similar to conventional magnetic tapes (differing only by the addition of lubricant layers), newer tape constructions for continuous loop applications provide the benefits of the more dependable oxide dispersions used in advanced instrumentation and computer tapes. Such heavy duty oxide dispersions offer lower static charge build-up and greater wear resistance. When ruboff does occur from extended use, the wear products from this more rugged oxide coating take on the consistency of a fine transitory powder—rather than the gummy “balling” consistency of conventional coating wear products. This virtually eliminates oxide buildup at the head gap . . . a common cause of output loss due to head-to-tape separation.

LUBRICANT COATINGS

Double-coated tapes, in addition to requiring a magnetic coating on each surface, must have an external lubricant on each surface to maintain uniform head-to-tape separation and consequently uniform frequency response on both tape surfaces. Single-coated tapes require only one surface externally lubricated and one oxide coated. Tape bulk is thereby reduced, providing a 20% thinner tape.

SPACE FACTOR CONSIDERATIONS

<i>Typical Single-Coated Tape</i>		<i>Typical Double-Coated Tape</i>	
Backing:	.92 mil	Backing:	.92 mil
Magnetic Coating:	.43 mil	Magnetic Coating	
External Lubricant:		(.38 mil ea. side):	.76 mil
	.10 mil	External Lubricant	
Overall Thickness:		(.07 mil ea. side):	.14 mil
	1.45 mil	Overall Thickness:	1.82 mil

This 20% thinner caliper possible with single-coated tape permits greater length over double-coated tape for any given occupied volume; and more important, provides a smaller ratio between inner and outer circumferences for any given tape length.

For example, in a given size roll (same inside and outside diameters), tape length is inversely proportional to tape thickness. Thus, 1200 feet of double-coated tape (a common length for continuous loop application) occupies the same space as approximately 1500 feet of single-coated tape of the thickness sample shown above. However, the length of single-coated tape to occupy the same space in a continuous loop application, is, in fact, 1700 feet long (also supplied as a common continuous loop length). The additional 200 feet can be included in the slack loop without increasing circumference, by virtue of more compact “winding” possible—resulting from the lower layer-to-layer resistance of tapes magnetically coated on only one side.

While double-coated tape is used in a mobius loop configuration, thereby doubling its effective length (to 2400 feet in this example), at a given tape speed the mobius loop cycle would be only 40% longer than the one-surface cycle of a single-coated tape ($\frac{2400-1700}{1700}$); not 100% longer as might have been assumed.

In the manufacture of externally lubricated tapes, current techniques strive to apply a lubricant coating which will be as thin and uniform as possible, provide the least mechanical resistance, yet adhere firmly to the tape. When lubricant rubs off (especially from double-coated tapes) lubricant particles tend to build up on the capstan and pressure roller until the capstan cannot drive the tape at a constant tape speed, resulting as objectionable wow and flutter. Also, lubricant ruboff on double-coated tapes introduces a buildup of lubricant particles at the head, spoiling good head-to-tape contact and resulting in poor high frequency (short wavelength) response. This compounds the already less-than-optimum response brought about by the minute separation between oxide coating and the head, existent as a result of the .07-mil lubricant coating.

On single-coated tapes the lubricant coating is applied to the backing material, not to the oxide coating, and therefore can be applied in a more generous layer (.10 mil) for more efficient and longer lasting lubrication, with less danger of tape slippage at the capstan. Also, since the oxide coating and magnetic head are in direct and intimate contact, short wavelength output is not

affected. At one-mil wavelengths, the .07-mil separation on double-coated tapes creates a loss of about -6 db from single-coated lubricated tapes:

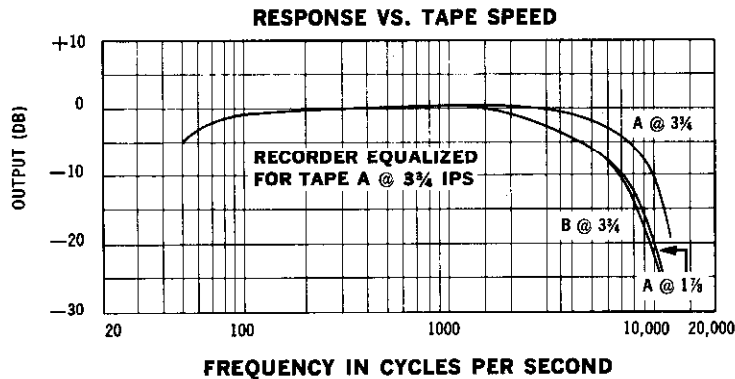

Due to better head/tape contact single-coat construction (tape A) shows slightly better high frequency output at half the tape speed of double-coat construction (tape B).

TAPE SPEED VERSUS FREQUENCY RESPONSE

It can be seen in these curves that the more intimate head-to-tape contact of single-coated tape permits using a tape speed of half that required for good response from double-coated tape, with no loss of high frequency response in the audible range spectrum. By exploiting this ability to operate satisfactorily at lower tape speeds, thinner, single-coated lubricated tape in any given size of slack loop (tape volume), can actually provide 30% longer playing time with essentially equal response character compared to an equal volume of double-coated tape.

	Length	Tape Speed	Time Per Tape Cycle
Example: Single-Coated Tape:	1700'	1.875 ips	3:01:12 hours
Double-Coated Tape:	1200'		2:08:02 hours
		x2(both sides)	
	<u>2400'</u>	3.750 ips	

This advantage of single-coated lubricated tapes, along with the "cleaner," less critical operation, are the bases for further research in magnetic tape for continuous loop recording.

Thinner backing materials (in the area of .5 mil thicknesses) have already experienced successful test use which will further enhance one-side coated lubricated tape applications. And current laboratory evaluation of more efficient lubricants indicate the probability of still greater playing times through added length with minimum wear of either magnetic or lubricant coatings.