

# ELECTRO ACOUSTIC Measurements



Brüel & Kjær





# Audible Sound



## RECORDING AND REPRODUCTION

Since the very introduction of electronic sound reproduction, ever increasing demands have been placed on the quality and fidelity of the reproduced sound. The greatest single influence on these demands was the introduction of FM, and later stereophonic, radio broadcasting. These transmissions brought concert hall quality into the living rooms of a vast and critical audience where the necessity of a high fidelity reproduction system was very quickly realised. The latter years' semi-electronic music, where musicians use a wide variety of electronic instruments, pick-ups, amplifiers, delay lines etc., to add new dimensions to their sounds, has further increased the demands on the audio electronic industry in terms of high performance equipment.

Thus, a situation exists where it is almost impossible to market a reproduction system which merely reproduces sound. Today's equipment must fulfill strict requirements to noise level, distortion, impulse response, frequency range etc., before it will be considered by a prospective purchaser. Subjective judgement is in many cases an excellent means of quality classification and in fact will always influence the ultimate decision. However, when questions are raised regarding development, production control, fault finding and documentation of a system's capabilities, then objective measurements have to be made. The purpose of this leaflet is to describe how the Brüel & Kjær range of measuring instruments can assist in the realization of truly high fidelity by objective means within this field – the field of electroacoustics.

## ELECTROACOUSTIC MEASUREMENTS

Measurements on the wide variety of electronic devices used to create Hi Fi sound, are all concerned with determining the changes made to the sound program from its first recording to its final reproduction. Any system used for measurement in electroacoustics can, therefore, be divided into a transmitting section, supplying a well defined signal, and a receiving section, measuring the characteristics of this signal after it has passed through the device under test. The scheme on the opposite page indicates the instrumentation possibilities with Brüel & Kjær instruments and also indicates the recording and display devices available.

### THE TRANSMITTING

section may consist of generators supplying sine, random noise, bands of random noise or swept narrow band random noise signals, or it may supply signals from, for instance, tapes or records with pre-recorded test signals.

### THE RECEIVING

section may, in the case of electronic measurements, consist of a variety of voltmeters, measuring amplifiers or frequency analyzers. For acoustic measurements a condenser microphone assembly is added.

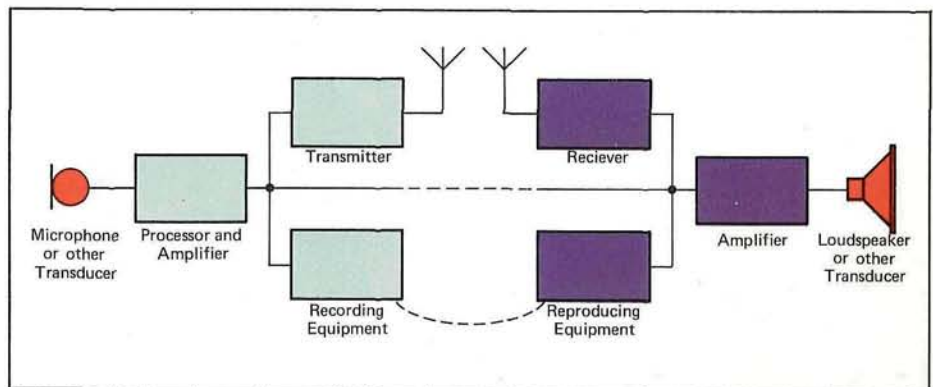

Basic organization of an audio reproducing system.







TYPE 1022  
SINE OUTPUT  
20 Hz TO 20 000 Hz  
COMPRESSOR



TYPE 1024  
SINE OR BAND NOISE  
20 Hz TO 20 000 Hz  
COMPRESSOR



TYPE 1615  
THIRD OCTAVE FILTERS  
25 Hz TO 20 000 Hz



TYPE 1405  
WHITE OR PINK NOISE  
20 Hz TO 20 000 Hz



TYPE 2010  
SINE OUTPUT  
2 Hz TO 200 000 Hz  
DISTORTION < 0.01 %



**TRANSMITTING SIDE**

TYPE 2706  
POWER AMPLIFIER  
MAX OUTPUT 75VA



TYPE 4712  
AUTOMATIC X POSITION  
50 dB RANGE  
20 Hz TO 20 000 Hz

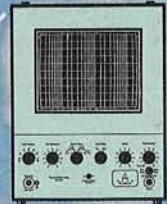

TYPE 7003/4  
FM OR DIRECT  
TWO OR FOUR  
CHANNELS, BATTERY  
OR MAINS OPERATED



TYPE 2307  
4 TO 2 000 mm/sec  
DC TO 200 000 Hz



**RECORDING**

**READOUT**

TYPE 7502  
DIGITAL RECORDER  
10 000 8 BIT WORDS



TYPE 6301  
MAX 75 CHAR/MIN  
TWO CODES

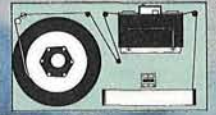

TYPE 2425  
0.5 Hz TO 500 000 Hz  
PEAK RMS AVERAGE



TYPE 2607  
2 Hz TO 200 000 Hz  
AC & DC OUTPUT



TYPE 2020  
3 Hz TO 100 Hz BANDWIDTH  
REJECTION



**RECEIVING SIDE**

TYPE 2107  
20 Hz TO 20 000 Hz  
6 % TO  
29 % BANDWIDTH



TYPE 2120  
2 Hz TO 20 000 Hz  
1 % TO  
23 % BANDWIDTH  
REJECTION



TYPE 2113  
25 Hz TO 20 000 Hz  
AC & DC OUTPUT



TYPE 2010  
2 Hz TO 200 000 Hz  
3 Hz TO 1000 Hz  
BANDWIDTH  
TRACKING BFO



TYPE 3347  
REAL-TIME  
25 Hz TO 20 000 Hz  
STORAGE MODE  
A & D OUTPUTS





# Frequency Response

The measurements described can all be made to fulfill the requirements in the German standard DIN 45 500 sheet 7 for Hi-Fi loudspeakers or loudspeaker combinations. This standard is probably the most widely used standard in Western Europe, but due to the flexibility of the instruments, measurements can easily be made to most other standards.

## FREQUENCY RESPONSE

The frequency response of loudspeakers may be measured in many different ways, since both sine, band noise and white noise can be used. The DIN standard 45 500 recommends 1/3 octave bands of pink-weighted random noise. This type of signal can be generated very easily and with a high degree of accuracy by a combination of the Noise Generator Type 1405 and the Band Pass Filter Set Type 1615. The Noise Generator can produce both "pink" and "white" noise in the entire audio range.

The advantage gained by this noise band excitation compared to single frequency signals is that narrow resonance phenomena are to some extent averaged out on the receiving side. The radiated sound-pressure is converted to electrical signals by a condenser microphone assembly. The microphone cartridge should be of the free-field type which internally compensates for the disturbance created in the sound field by its presence. The signal is then fed via a Measuring Amplifier, e.g. Type 2606, to the Level Recorder Type 2305 or Type 2307.

In cases of dominating background noise, the Audio Frequency Spectrometer Type 2113, which includes a measuring amplifier, may be used to increase the noise immunity considerably.

However, the mentioned standard requires an additional measurement carried out with a sine excitation swept in the range between the axial resonant frequency and 250 Hz.

This low frequency response check can be performed by the same set-up if the Noise Generator is replaced by the Beat Frequency Oscillator Type 1022 or the Sine Random Generator Type 1024.

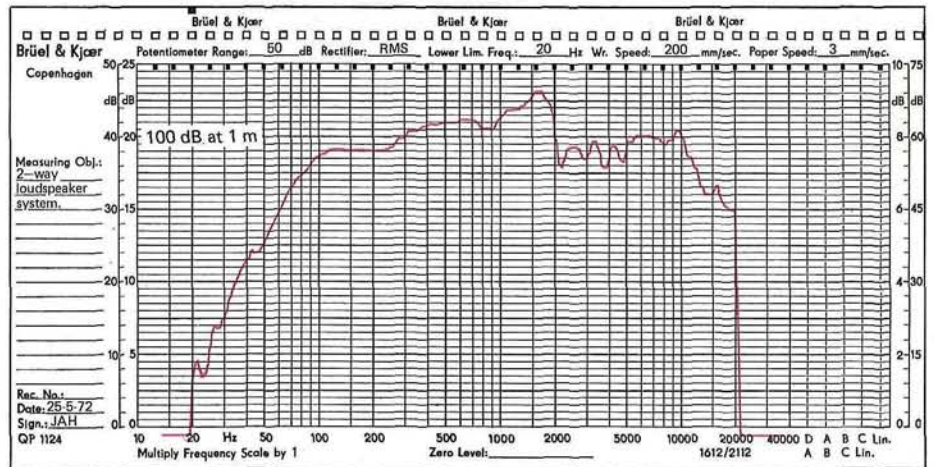
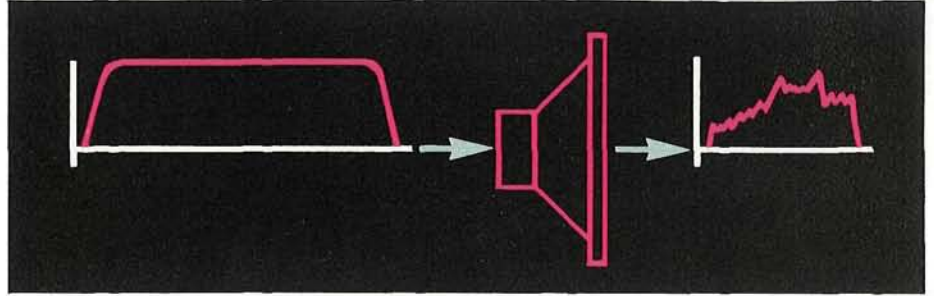

Sine response of a medium-quality, two-way loudspeaker system.

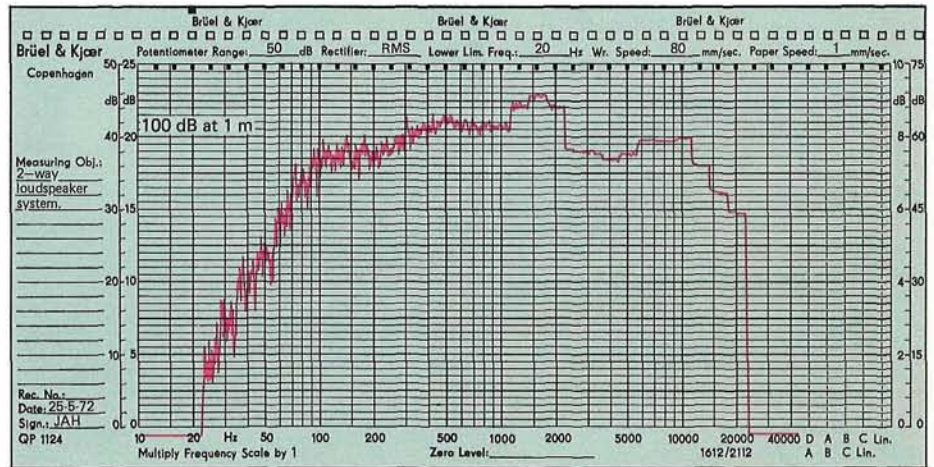

Response of same loudspeaker system excited by pink-weighted, 1/3 octave filtered random noise.

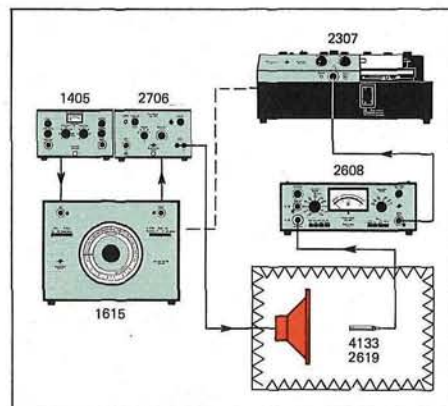
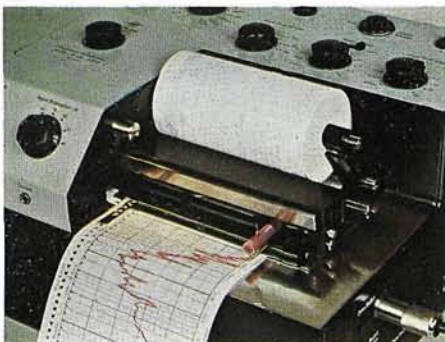

Set-up for response measurements utilizing narrow bands of noise.

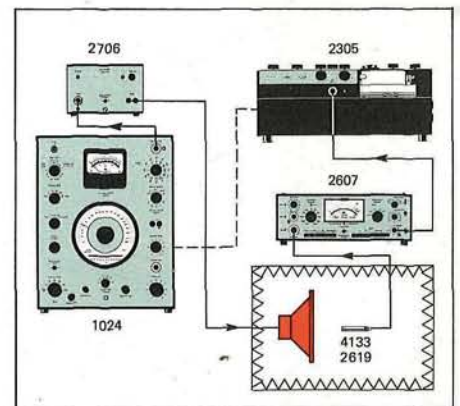

Set-up for sine or swept narrow-band noise measurements.



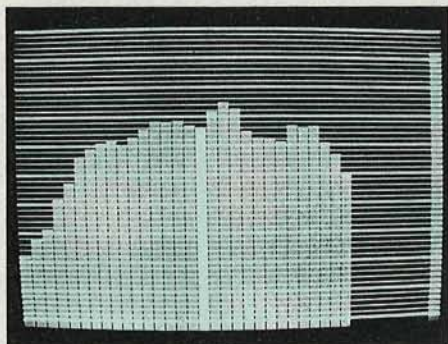

Response to pink noise displayed on Real-Time 1/3 Octave Analyzer Type 3347.

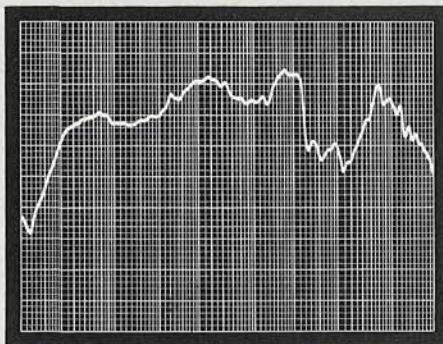

Sine response of same system displayed on Frequency Response Tracer Type 4712.

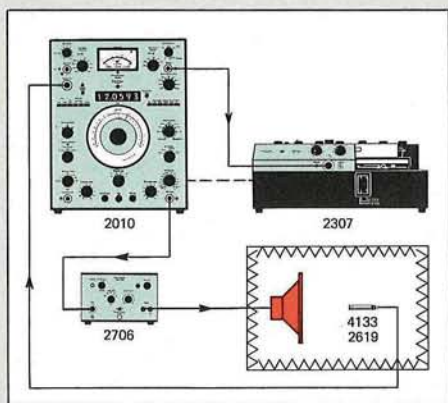

Two set-ups where the selective receiving sides are automatically tuned to the excitation frequency.

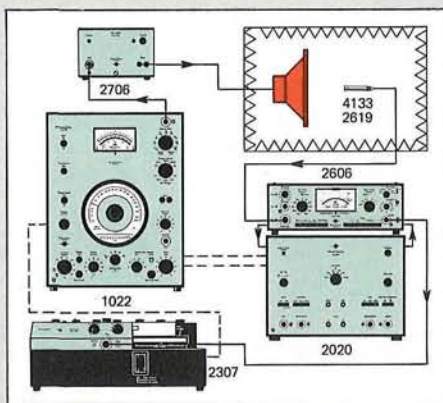

## PRODUCTIONS CONTROL

Often it is desirable to perform a total production test. In this case The Real-Time 1/3 Octave Analyzer Type 3347 is a very favourable choice, since the advantages of random excitation can be combined with those of instantaneous read-out. Furthermore, printed documentation can still be obtained. Due to the store-mode of the analyzer the printout and the exchange of test object may take place simultaneously making an extremely high test rate possible without sacrifice of accuracy or flexibility. If sine excitation is acceptable and printed documentation is not required, the Frequency Response Tracer Type 4712 can be used as read-out device. With this instrument any desired range between 20 and 20 000 Hz may be swept at a rate ranging from approx 1/3 octave per second to 3 decades per second.

Forward and reverse sweep speeds and the sweep limits are continuously adjustable on the Response Tracer.

## OTHER SET UPS

The B & K Heterodyne Analyzer Type 2010 may be used both as a sine excitation generator and as a selective receiving section since it generates a sine wave with extremely low distortion exactly at the frequency to which it is tuned.

The Heterodyne Slave Filter Type 2020 may be used in much the same way as it is automatically tuned to the generator frequency; suitable generators are the Types 1022 and 1024.

Due to the fact that there is a certain time delay dependent on the loudspeaker - microphone distance, one must be sure that the sweep is not so fast and/or the filter not so narrow that the frequency of the received signal is outside the filter passband.

This frequency offset effect can, however, be used to perform free-field measurements in normal reverberant rooms. If the distance from the speaker to the nearest reflecting surface and on to the microphone is large compared to the direct distance, then the scanning speed and the bandwidth may be selected in such a way that the direct signal is inside, and all reflected signals outside the passband.



## RECORDED TEST SIGNALS

As well as the test procedures required by the standards, manufacturers will often wish to perform additional measurements on their products in order to obtain information regarding properties which are known to be critical. Since several different signals may thus be required, it seems reasonable to use a tape recorder loaded with a "homemade" tape as signal source. A separate tape may be developed for each type of product.

If convenient, the response may be recorded on another track of a multichannel tape recorder.

Synchronism between the recorded program and the Level Recorder is obtained automatically with the aid of the Response Test Unit Type 4409 if a 1000 Hz burst is recorded in advance of the test.





# Polar Plots

It is, of course, important to know if the radiated sound pressure is sufficiently uniformly distributed in all the directions where listeners might place themselves. Valuable insight into this behaviour of a speaker system is gained by recording its directional characteristic.

The recording can be very easily made with the aid of the Turntable Type 3922, and the Level Recorder loaded with polar paper charts. The Turntable has slip rings for the transfer of line power and signal voltage whereby twisting of wires and cables is effectively avoided. Synchronization between the Table and the Recorder is performed by a single cable and a rotation sequence can be started from either of the instruments.

## IMPEDANCE

Since most of the B & K oscillators and generators provide compressor regulation facilities, which may effectively convert them from voltage to current generators, they are ideally suited for automatic impedance plots of loudspeakers. The acoustic environment will influence this measurement and several standards (e.g. IEC 200, DIN 45 573 sheet 1 and BS 2498) are concerned about specifying the preferred conditions.

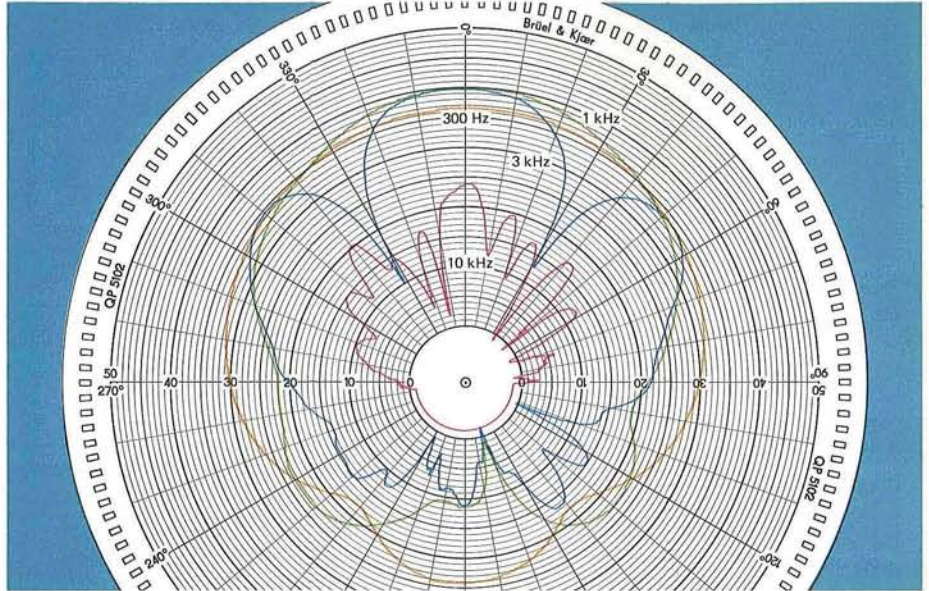

Polar plot of medium quality, two-way loudspeaker system.

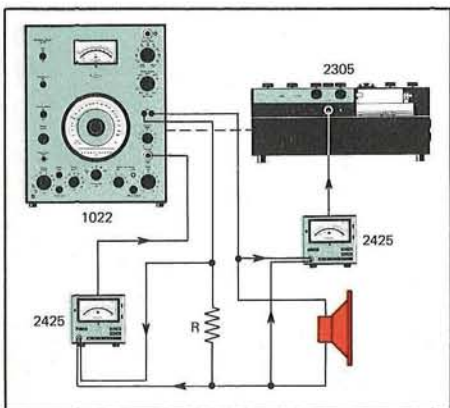

Arrangement capable of measuring the frequency dependence of the loudspeaker impedance.

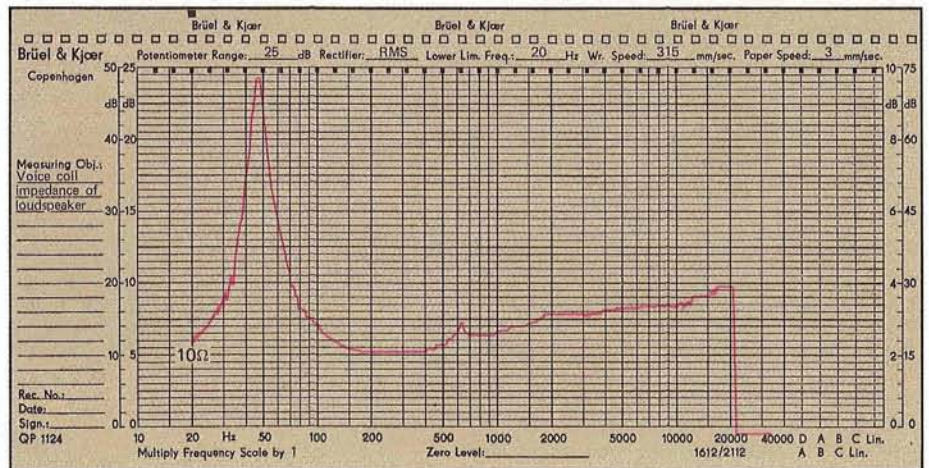



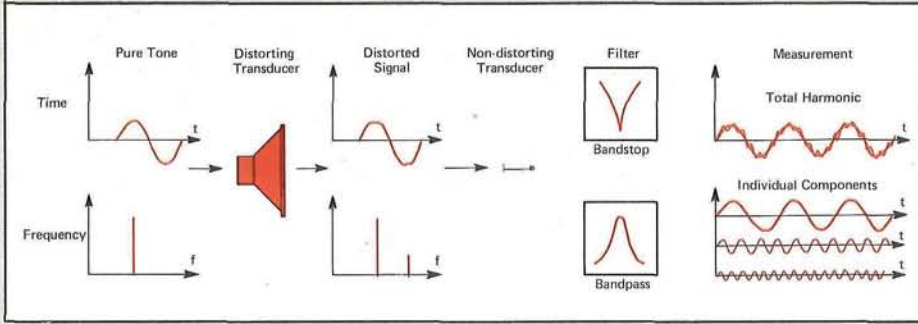

Sketch showing different principles in distortion measurements.

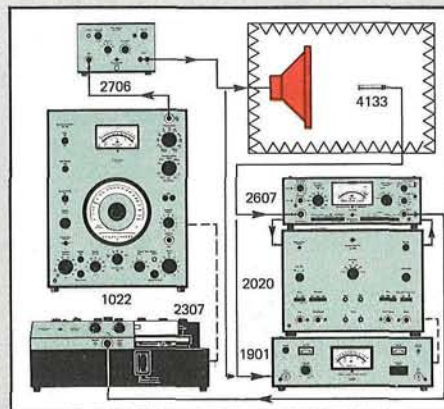
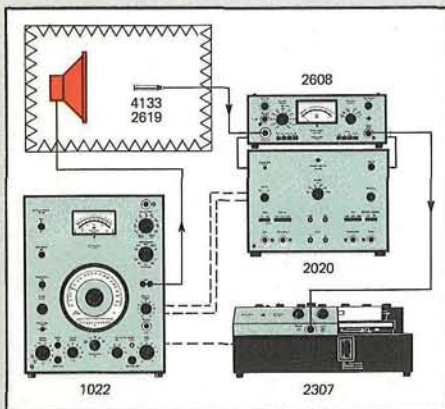
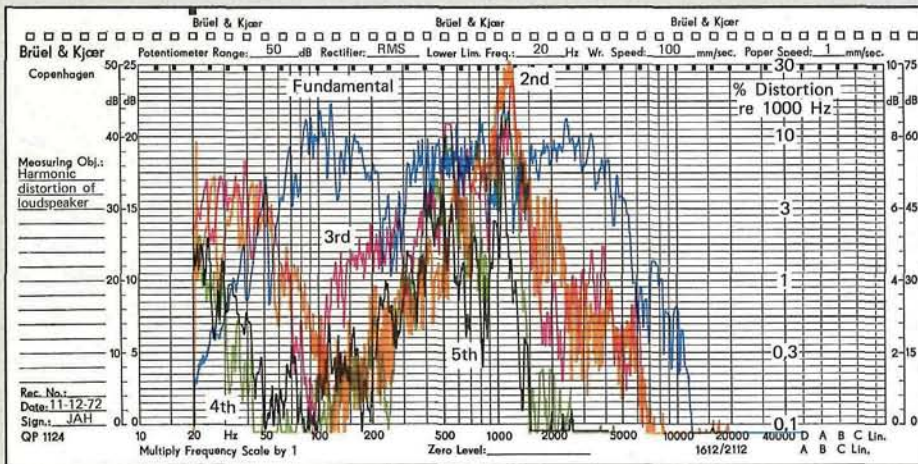
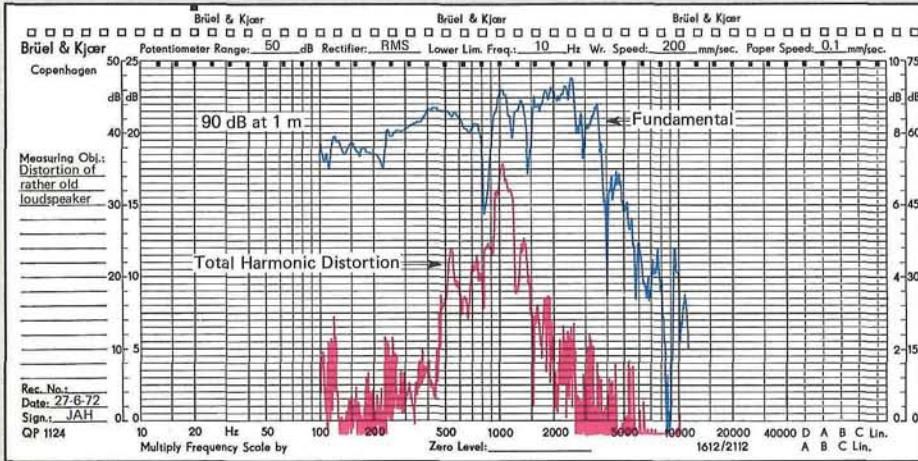

Ideally, a loudspeaker is a linear device which creates a sound pressure proportional to the voltage across its voice-coil. Several imperfections are involved however. The magnetic field is not linear, the suspension will normally exhibit a hardening characteristic and the cone can only be considered rigid in a limited frequency range.

When a program is transmitted through such a nonlinear system, the ratio between a tone and its harmonics will be changed and new frequency components, not originally present, will be generated.

## HARMONIC DISTORTION

DIN 45 500 demands a plot of the total harmonic distortion. A set-up which meets all the DIN requirements may be composed of the Beat Frequency Oscillator, the Heterodyne Slave Filter Type 2020 and one of the Measuring Amplifiers. The Slave Filter is used in the rejection mode which leaves only the distortion components to be measured.

If the distortion is to be determined at discrete frequencies only, then the Frequency Analyzer Type 2120 will prove very advantageous. Used in the rejection mode, the total harmonic distortion will be indicated and if the bandpass position is utilized, the amplitude of the individual components can easily be obtained on the Level Recorder.

In all cases where harmonic distortion is to be measured, it is essential that the generator distortion does not contribute to the measurement results.

The most complete impression of the distortion is obtained by plotting the magnitude of the individual harmonic components vs. frequency. This is possible with the aid of the Tracking Frequency Multiplier Type 1901. This instrument is able to tune any of the filters Type 2010, 2020 or 2021 to harmonic components with index numbers in the range from 0,1 to 99,9 or 1 to 999 in steps of 0,1 or 1 respectively dependent on the filter utilized.

The only input required by the Frequency Multiplier is either the pure excitation signal or the distorted, but still periodic, output from the device under test. This great flexibility allows detailed analysis of distortion to be carried out in many situations where it was not previously possible.

A fast check of the distortion may also be obtained on the Real-Time 1/3 Octave Analyzer Type 3347. The large display will immediately indicate the effect of external adjustments or corrections. If the fundamental frequency is rejected by a separate filter, the dynamic range of the measurement will be increased considerably.





# Distortion-Efficiency

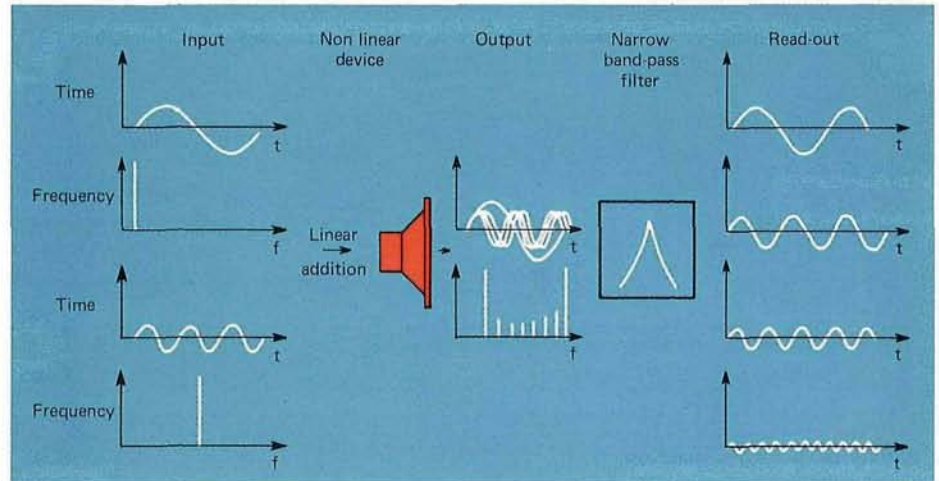

## INTERMODULATION

If two or more frequencies are transmitted through a nonlinear system simultaneously, new components will be created.

For the measurement of this type of distortion the Heterodyne Analyzer Type 2010 is a very powerful tool. Constant bandwidths can be selected in the range from 3.16 Hz to 1000 Hz, and the centre frequency can be tuned from 2 Hz to 200 000 Hz. Thus a very detailed analysis of modulation products can be obtained.

Since the fundamental frequencies need not be harmonically related, the distortion of the individual signals is of limited importance.

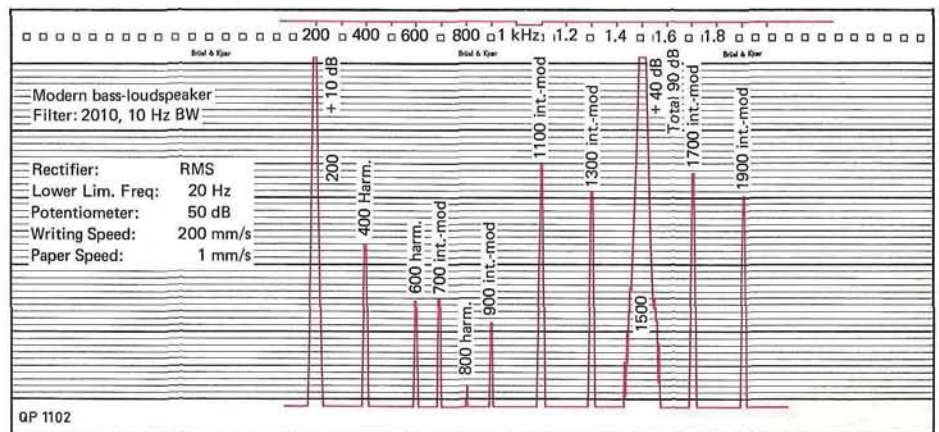

## EFFICIENCY

The efficiency of a loudspeaker is usually very low, typically about one per cent. The exact figure can be calculated by integrating the three dimensional free-field sound pressure characteristic. Since, however, this is often strongly dependent on frequency and, furthermore, highly irregular, the method is not very useful in practice. A much easier method to determine the efficiency can be used if a reverberation room is available. The method utilizes the fact that in such a room there is a simple relationship between the sound pressure and the supplied power. This relation only requires the knowledge of room volume and reverberation time.

If the speaker under test is excited by third octave pink weighted noise, a plot of the efficiency as a function of frequency is easily obtained. The receiver side may contain the Spectrum Shaper Type 5587 to eliminate the effect of changes in reverberation time with frequency.

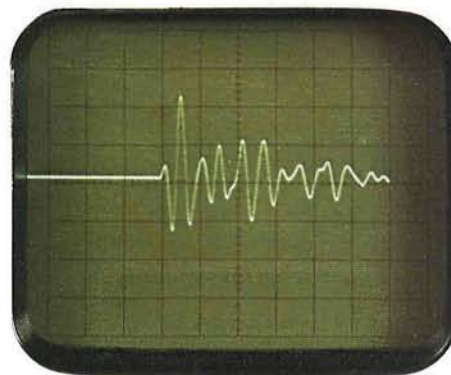

Response display on oscilloscope.

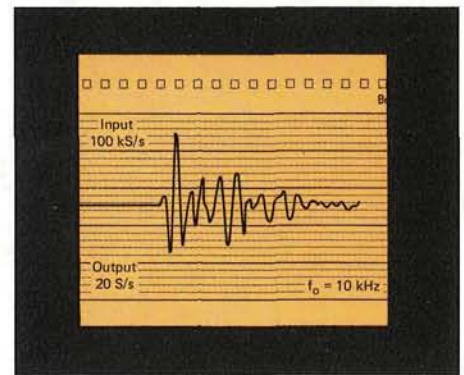

Impulse response read-out on level recorder.

## IMPULSE RESPONSE

In recent years the impulse response of loudspeakers has gained considerable attention. This is mainly due to the limited correlation which exists between the traditional objective measurements and the subjective quality evaluation found by listener tests.

For this type of test a squared sine pulse is very useful, since its spectrum is flat below a corner frequency determined by the sine argument, and because it contains very little energy above this frequency.

For the recording of the response B & K has recently developed an ideal instrument, the Digital Event Recorder type 7502. The memory in the 7502 can contain up to 10 000 words of 8 bits each. The replay can be speeded up and repeated, making the response suitable for oscilloscope observation, or it can be slowed down for pen recording purposes.

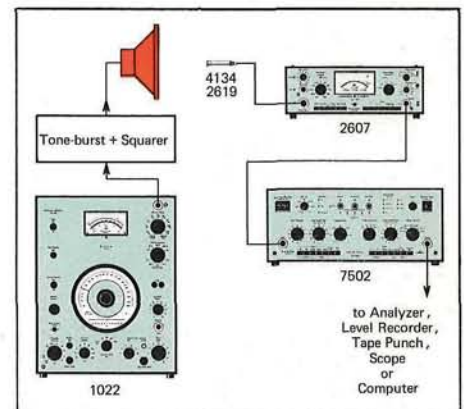

Set-up for the recording of impulse response.



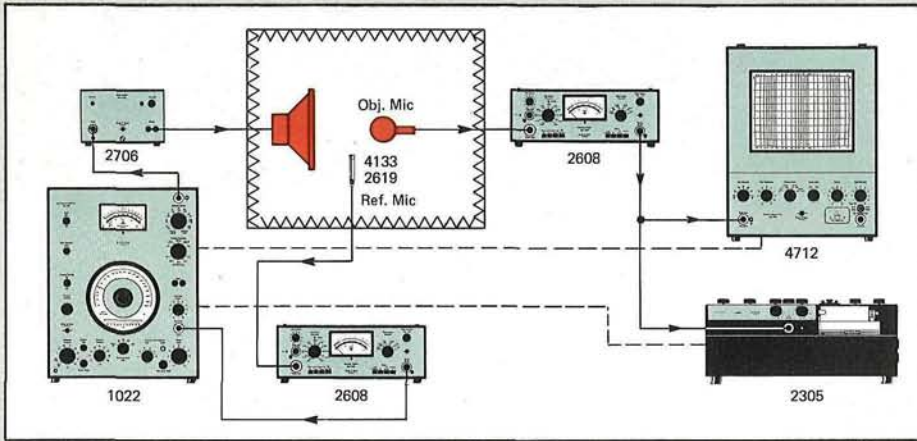

Arrangement for the determination of the frequency response of a microphone.

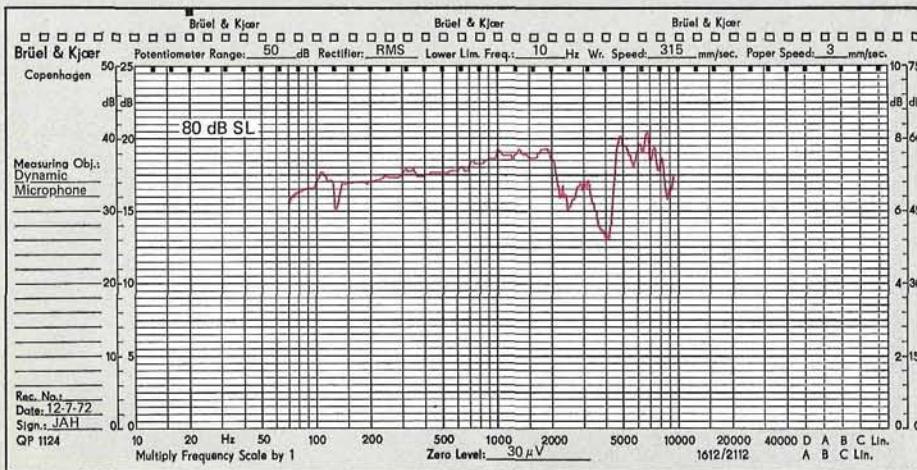

Response of ordinary, inexpensive dynamic microphone.

When the properties of microphones are to be determined, the input must of course be an acoustic signal with well known properties. These signals are far more complicated to generate than the electrical signals used when loudspeakers, amplifiers, tape recorders etc. are tested.

## FREQUENCY RESPONSE

One of the more important characteristics of a microphone is its frequency response. In DIN 45 500 sheet 5, restrictions are put on both the theoretical and the actual curve. To perform a measurement of the sensitivity as a function of frequency, it is

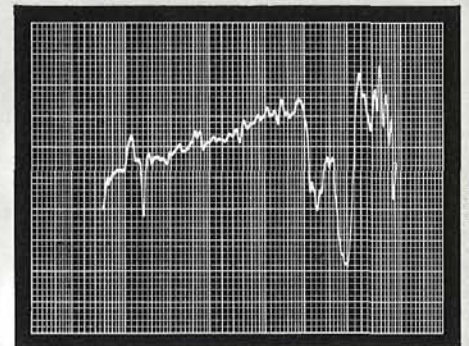

Response displayed on Response Tracer Type 4712.

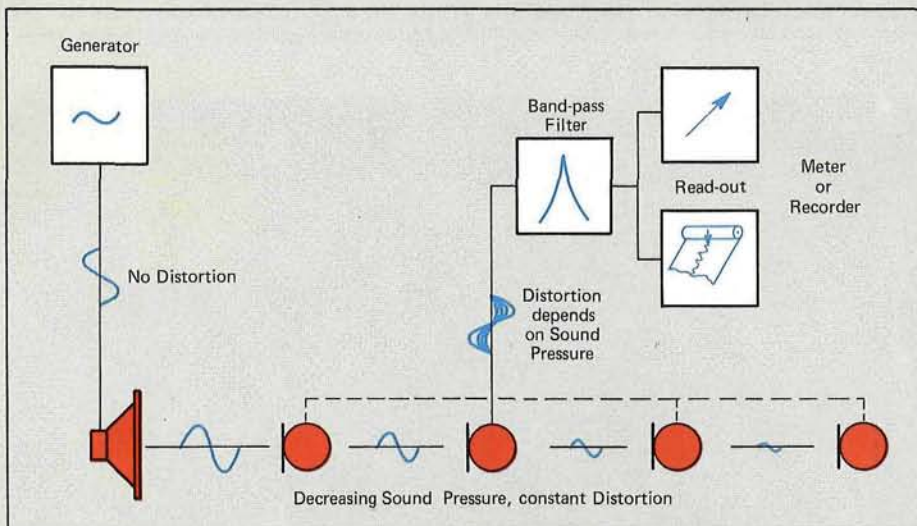

Principle of distortion measurements on microphones overcoming the demand of a pure sound field.

## DISTORTION

Due to the very small forces and displacement involved with the active parts of a microphone, the distortion at moderate sound pressures is not a major problem. Since, furthermore, a measurement of the harmonic distortion calls for a pure sound field, which is difficult to generate, this type of measurement has not gained wide spread use.

If a microphone is placed in a free sound field at a considerable distance from the loudspeaker, the output will possess a certain distortion. If the distance is reduced, the distortion will probably increase due to the increased sound level. If the distortion can be split into steady and distance dependent parts, the latter will be due to the microphone.

necessary to generate an acoustic field which is frequency independent. This can normally not be done directly. If, however, the sound level is monitored by a B & K Measuring Microphone placed close to the device under test, and if the electrical generator has an automatic gain or compressor circuit, the level will only depend on the reference microphone.

As signal source the Beat Frequency Oscillator Type 1022 or the Sine-Random Generator Type 1024 is very well suited, because of their continuous three decade sweep and compressor feature.

The resulting response curve can be plotted on the Level Recorder Type 2307 or it may be displayed on the screen of the Frequency Response Tracer Type 4712.

The generator is tuned mechanically by the Level Recorder which delivers the response on a chart of frequency calibrated paper, this may then be supplied with the tested unit as proof of the quality of the device.

When the Response Tracer is used, the same curve is obtained on the screen but the documentation is lost. The Tracer has a built-in frequency to voltage converter which automatically creates an X-deflection corresponding to the instantaneous frequency of the excitation.





# Distortion-Directional Characteristics

Another method is based on the traditional measurement of intermodulation. If two sound fields are generated simultaneously, then components at the sum- and difference frequencies present in the microphone output can only be generated by the microphone.

For this type of measurement the Heterodyne Analyzer is ideal since it has very wide dynamic range and narrow bandwidths.

The frequencies which should be used and the ratio between their magnitudes are at the present left to the choice of the manufacturer but the subject is under consideration in a commission under the IEC. DIN 45 500 also has restrictions on the tolerable microphone distortion, but does not deal with the methods of measurement.



## DIRECTIONAL CHARACTERISTICS

In many applications using microphones, it is of great importance to know the directional characteristic. With the microphone mounted on a Turntable Type 3922 it is extremely simple to obtain the desired plot on a special sheet of polar paper. DIN 45 500 requires different demands to be met dependent upon the type of microphone. Either of these tests can be performed with a set-up of the Turntable, an Oscillator, a Measuring Amplifier, and a Level Recorder.

If plots made at different frequencies must be compared directly, a compressor loop must be utilized to compensate for an imperfect frequency response of the loudspeaker.

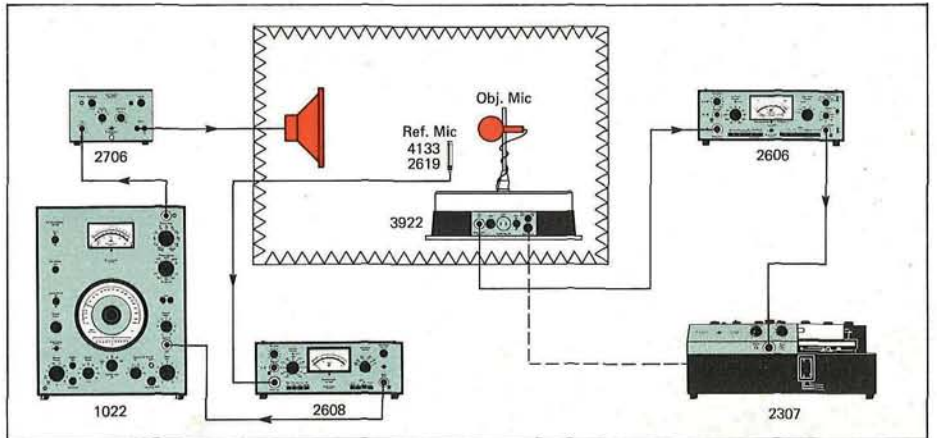

Set-up for recording directional characteristics of a microphone. The Reference Microphone and the Compressor Amplifier are not required if the plots may be recorded at different sound pressure levels.

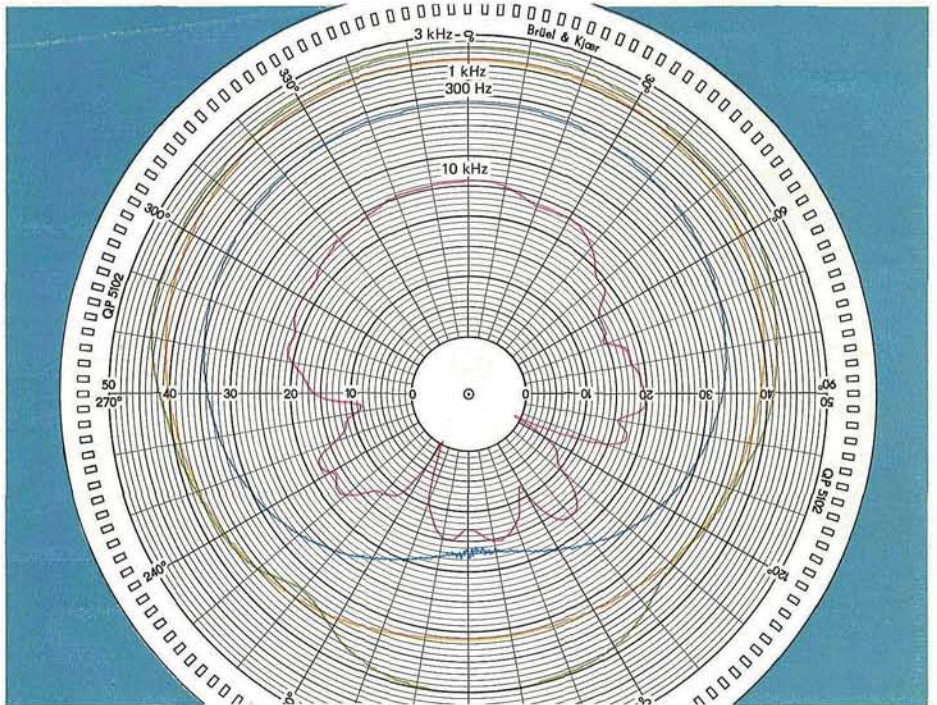
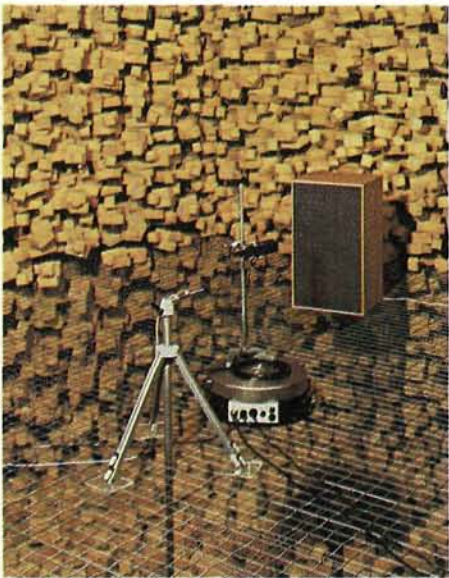

Directional characteristic of a dynamic microphone.



The mechanical system present in e.g. record players, may contribute to imperfections in the final program.

Two quantities are of importance. The first is the ability of the system to maintain a constant and accurate speed of revolution while the second is the degree to which the vibrations from the motor and the mechanical transmission system will create an output voltage from the pick-up.

## RUMBLE

For the purpose of production control and writing specifications for the customer, rumble is normally measured as the output

from the pick-up when an unmodulated groove is replayed, the output signal being weighted by passing it through a standard rumble filter. This filter is incorporated in the Record Filter Set Type 5583. In the development phase it is of great importance to analyze the rumble signal since this gives insight into which parts of the system one could suspect. For analysis of this kind the Frequency Analyzer Type 2120 should be used. Vibrations can be analyzed down to 2 Hz and the bandwidth may be chosen to be as narrow as 1%. The long averaging times which are required are also provided.

## WOW AND FLUTTER

B & K produces no instruments specially designed for wow and flutter measurements, but if an uncalibrated indication for comparison is sufficient, then a filter slightly detuned from the recorded frequency will give an impression of the level. If, e.g. the Heterodyne Analyzer Type 2010 is tuned to give a 15 dB reduction from the reading at the centre frequency, the 3.15 Hz filter will produce an output change of more than 60 dB per percent. Of course a reading of the centre frequency will indicate if the speed of rotation is within the tolerable limits.

## Pick-up Measurements

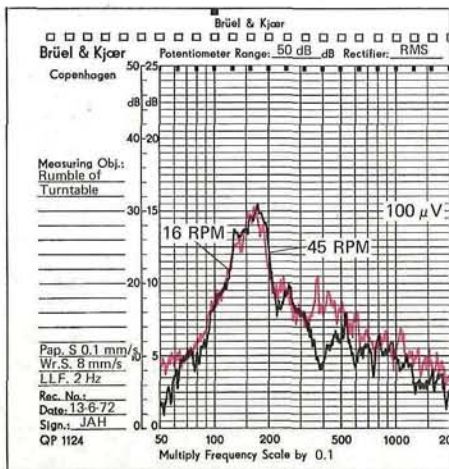

Turntable rumble at different speeds of revolution.



## PICK-UP

The pick-up converts the mechanical vibrations engraved in the groove walls of a recorded disc into electrical signals. The signal may be monaural or stereophonic and the pick-up must have properties in

accordance with this. A monophonic signal moves only laterally but a stereophonic signal will generally have both vertical and horizontal components.

## TEST RECORDS

The most common way to test pick-up units is to replay a well-defined test record. This method has some disadvantages which make it difficult to achieve accurate measurements. The material of the disc is subject to mechanical wear and the properties of the signal may change slightly as the groove speed decreases towards the centre.

Never-the-less, test records are still the preferred means when the performance of pick-ups must be measured.

The B & K Test Record QR 2009 is engraved with frequency sweeps from 20 Hz to 20,000 Hz. Four different types of modulation are available making it possible to perform a wide range of important measurements. Each band is preceded by a 1000 Hz calibration and synchronizing signal. When using the Response Test Unit Type 4409, the Level Recorder is activated at the start of the sweep.





# Frequency Response-Arm Resonances

With the aid of the Test Record QR 2009, frequency response measurements and measurements of the crosstalk become very simple matters. On bands 1 & 2 of the Test Record only one of the walls carries modulation. This means that both the frequency response and the crosstalk can be measured individually for the two channels.

## BALANCE

The chopping facility provided by the Test Unit may be used to examine the balance as a function of frequency. Replaying bands 3 & 4 in this mode will indicate the balance both in the horizontal and vertical directions. The balance measurement may also be regarded as a frequency response measurement.

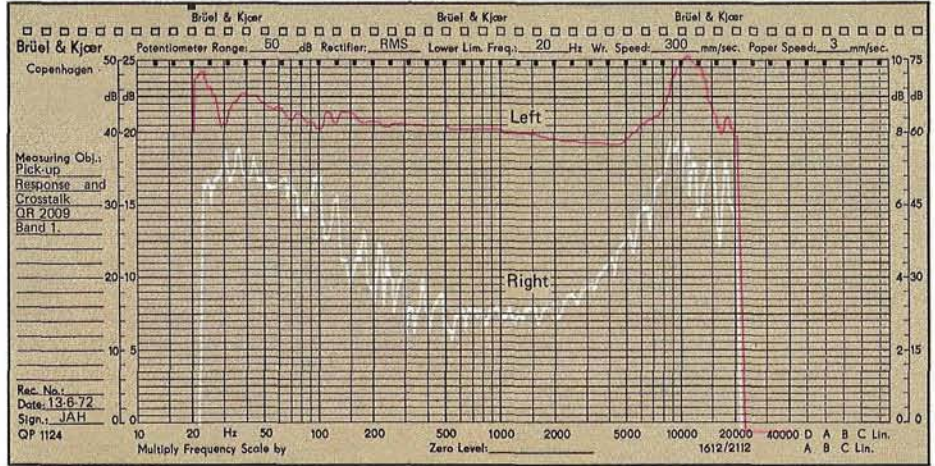

Plot of frequency response and crosstalk level of inexpensive stereophonic pick-up.

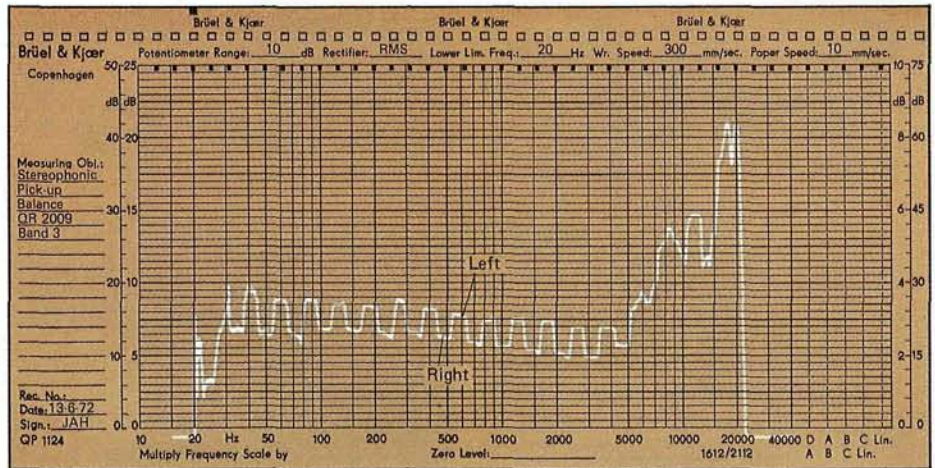

Balance of high quality stereophonic pick-up.

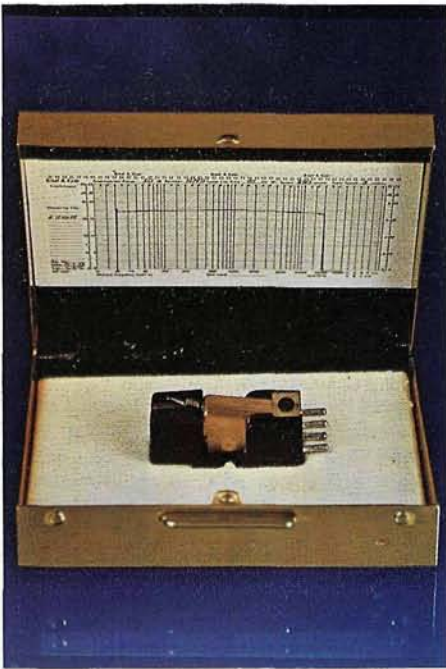

## ARM RESONANCES

It is important that the tuned circuit, consisting of the stylus suspension and the moment of inertia of the tone arm, is well damped and that the resonant frequency is kept outside the audible range. The Test Record may also be used for this kind of measurement if the speed of rotation can be reduced.

Test records for this kind of measurements are available from many manufacturers.





As a storage device, magnetic tape exhibits some advantages compared to discs. Tapes are less sensitive to mechanical damage; the signal can be erased and a new program recorded when desired and it does not limit the number of available channels, provided it has sufficient width.

The main disadvantages are lack of long term stability and print through effect. Various national standards call for different signal conditioning during recording and playback; the general principle is that the parts of the audio spectrum, where ordinary speech and music contain only

little energy, are given extra amplification. It is important to note that the necessary corrections are also functions of the tape speed. Test tapes, designed for the measurement of a wide variety of tape recorder properties, are available from many manufacturers.

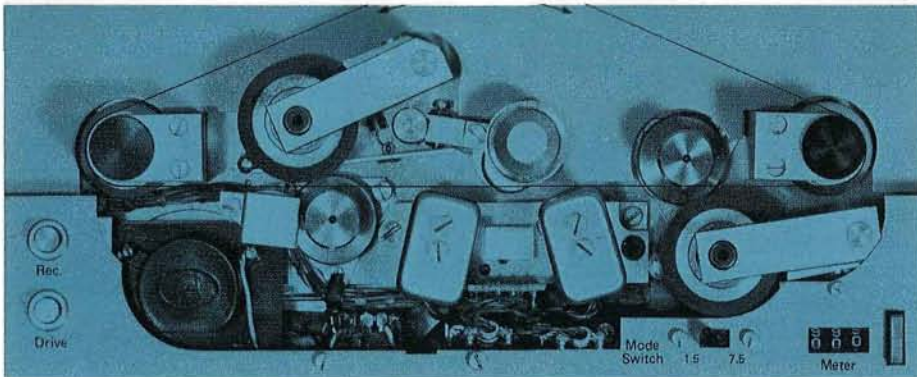

## FREQUENCY RESPONSE

Even very inexpensive tape recorders usually contain both a recording and a reproducing channel which may be made up of more or less common circuitry. In high quality equipment these circuits are separated.

The two circuits must generally be examined individually. The replay circuits can be tested with standard test-tapes. It is important, however, that the used test tape is valid in the country where the recorder is intended to be used.

With the aid of the Beat Frequency Oscillator Type 1022 a test-tape may be recorded on a standard device. The sweep should be logarithmic and cover the range from 20 Hz to 20 000 Hz in 47 seconds, in order to match the frequency calibrated paper of the Level Recorders Type 2305 and 2307. If preceded by a 1000 Hz synchronization burst and if the Response Test Unit is used, the signal will automatically start the sweep.

A test-tape containing a series of rapid sweeps may be used to display the playback response on the Response Tracer Type 4712. Since this instrument contains a frequency to voltage converter, this set-up is extremely simple. Furthermore, the fact that the response is continuously visible on the screen makes it possible to perform fast, easy, reliable and accurate response adjustments.

The frequency response of the recording amplifier cannot be measured alone without special measures, but if the replay characteristic is known, the overall response is sufficient. This curve can be measured in different ways dependent on whether or not the unit is designed for immediate playback. If so, the Level Recorder may be connected to the output and the Beat Frequency Oscillator to the input. At reasonable tape and scanning speeds, the frequency offset between input and output will be insignificant. If instantaneous replay is not provided, then the tape must first be recorded and replayed afterwards. The problem of synchronization of the frequency axes may again be solved by utilizing the Response Test Unit Type 4409.

The method of rapid sweeps and readout on the Response Tracer also applies in this case.

## AZIMUTH

Test tapes are often recorded with a signal intended for azimuth adjustments. If the tilt of the replay head is adjusted for maximum output when replaying this signal, the head will be aligned to the same angle as the one with which the tape was recorded. Once the replay head has been adjusted after this method, the record head may be aligned after much the same procedure ensuring that tapes can be interchanged between recorders without affecting the high frequency response.

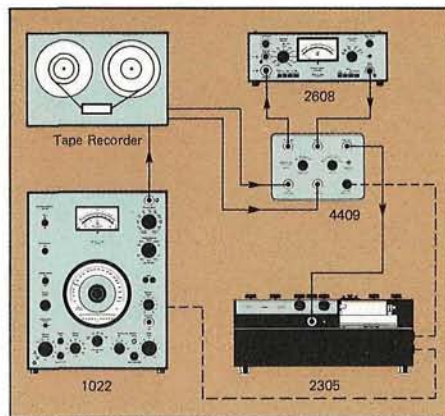

Set-up for frequency response measurements.

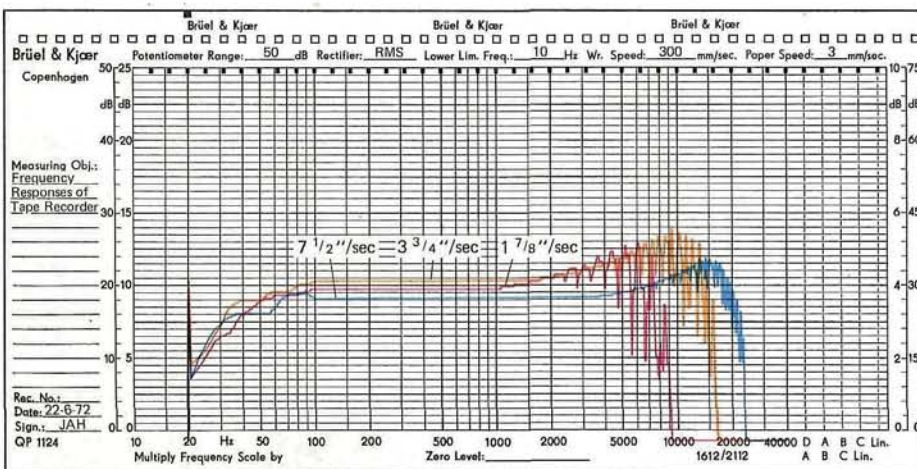

Frequency response curves of a tape recorder at various tape speeds. The peak at 20 Hz is the start-signal for the level recorder.





# Distortion-Hum and Noise - Crosstalk

## DISTORTION

In a well designed tape recorder the tape should be the only significant contributor to the total input-to-output distortion. The distortion of the amplifiers can be measured by very straight forward methods, but dependent on frequency, care must be taken to make the proper corrections due to pre- or deemphasis.

A measurement of the overall distortion may also be desirable and, in this case, no corrections are required.

Both the Heterodyne Analyzer Type 2010 and the Frequency Analyzer Type 2120 can be used with advantage if single frequency measurements are performed, due to their narrow bandwidths and their wide dynamic ranges.

Utilizing the Tracking Frequency Multiplier Type 1901 makes it possible to measure any desired harmonic and solves the problem of synchronization.

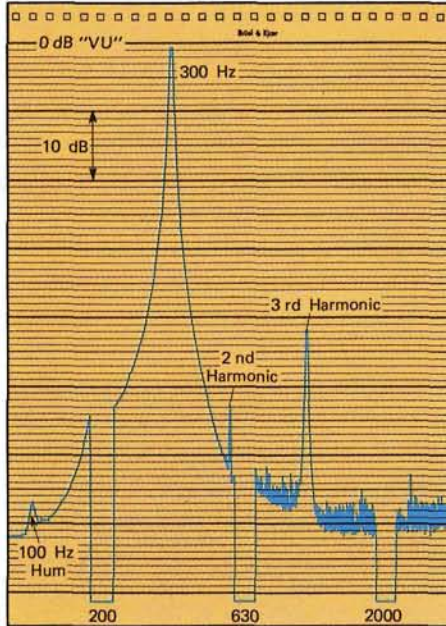

Distortion of a 300 Hz pure tone as reproduced by a tape-recorder. The Frequency Analyzer Type 2120 was used in the 3% Bandwidth position.

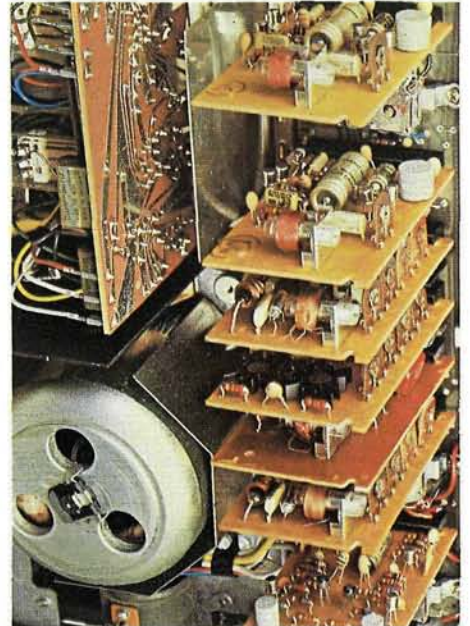

## HUM AND NOISE

Noise is generated in several ways in a tape recorder. In a well designed machine the main contributor to white noise generation is the tape. This is due to the fact that the magnetic material is not homogeneous but composed of small, discrete magnetic elements.

In mains operated units the amplifiers may pick up stray magnetic fields from transformers, motors etc. This is most likely to happen in the replay head due to the weak signal and the heavy low frequency deemphasis at play back.

A frequency analysis of the output both with and without the tape in normal operation will indicate the severity and, to some extent, the origin of hum-signals.

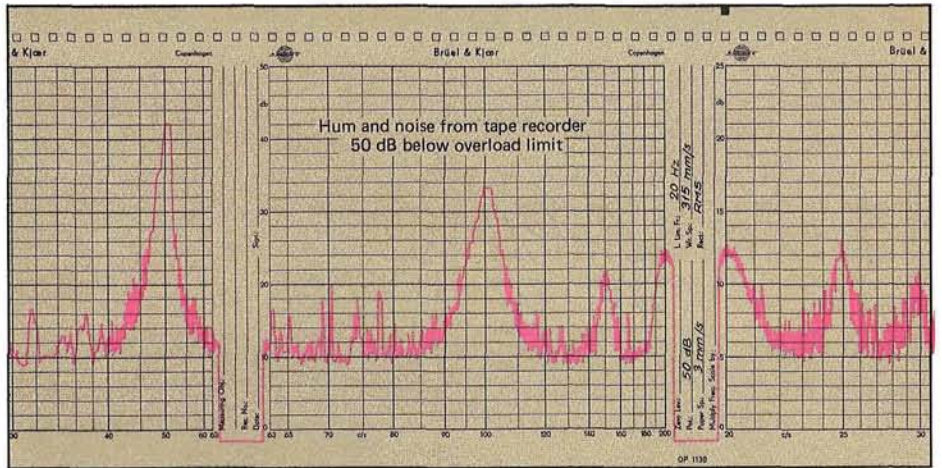

Noise and hum characteristics of a good quality tape recorder. At higher frequencies the output will increase at 3 dB/octave due to white noise.

## CROSSTALK

A special type of undesired signal may be present in multichannel tape recorders where signals recorded on one channel are also present on the others.

This effect is usually a function of frequency. In cases where the crosstalk is low, it may be measured by recording narrow band noise in e.g. third octave steps. During playback, the Response Test Unit may be utilized to obtain synchronization between the selective measurement set-up and the recorded program.

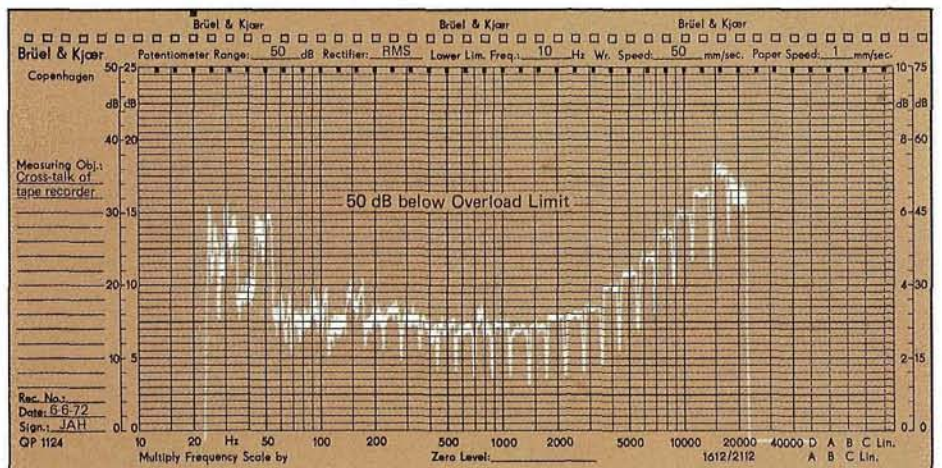

Tape recorder crosstalk recorded with selective receiving side in order to avoid hum components.



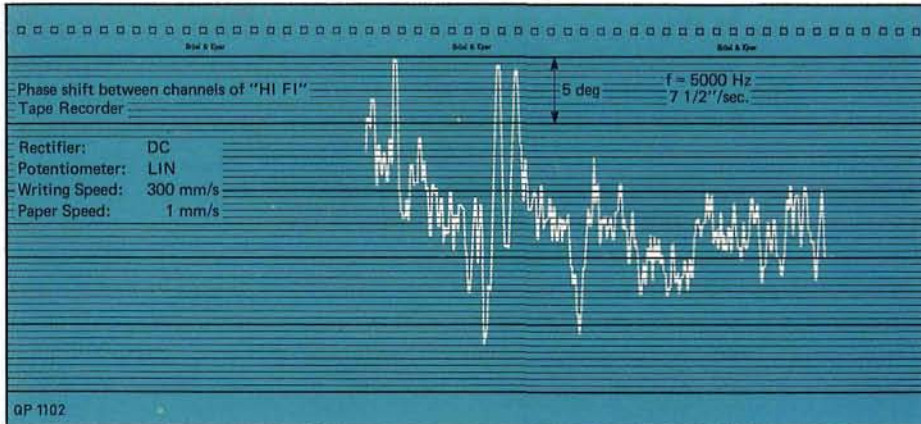

Phase shift between channels of a "HI FI" tape recorder. One of the signals is given an initial phase shift to avoid fluctuations around zero.

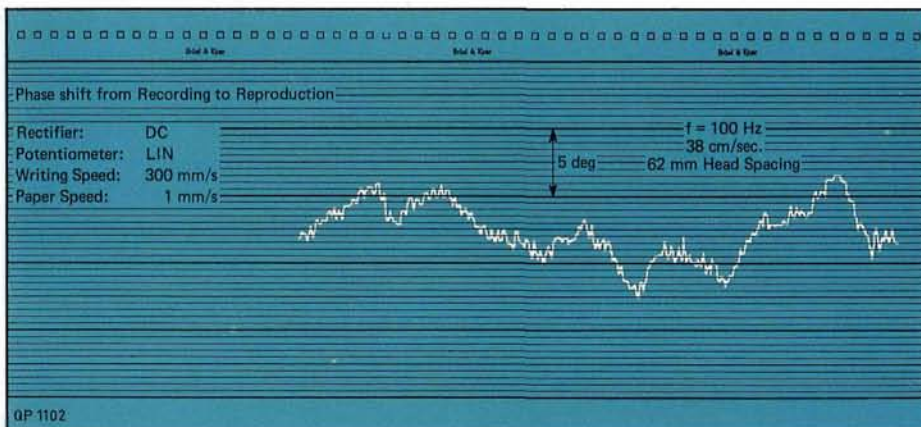

Recording of the fluctuations in phase shift from recording to reproduction of a professional tape recorder.

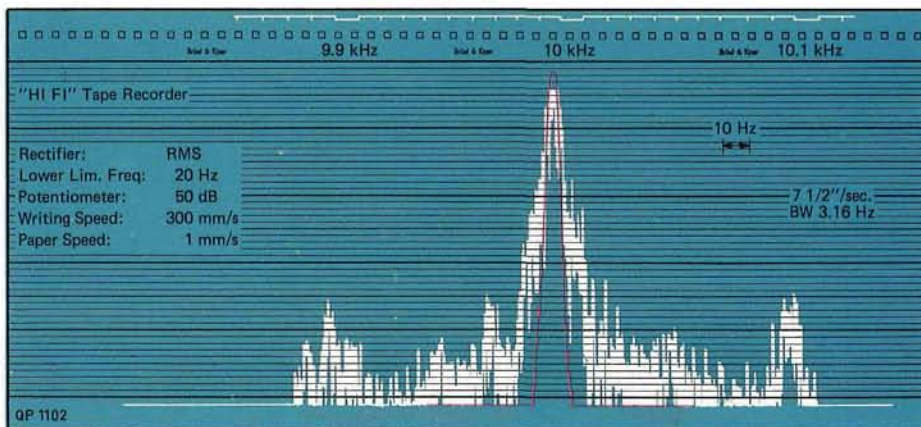

Analysis with the Heterodyne Analyzer Type 2010 of a recorded and reproduced pure tone.

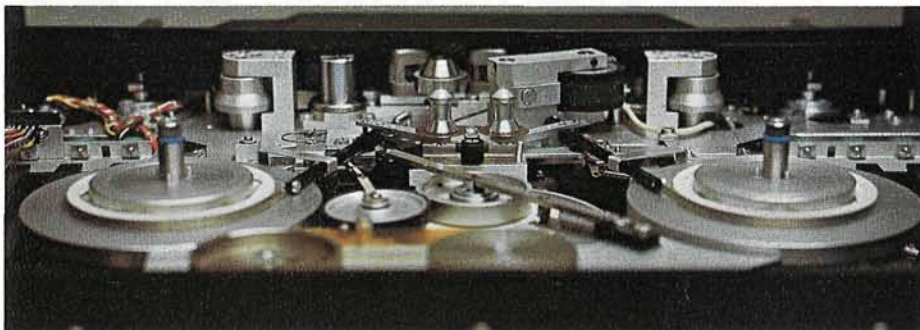

## MECHANICAL CHECK

A valuable check on the performance of a transport system can be obtained on multitrack tape recorders by applying the same sine signal to two different channels and measuring the phase deviation between the signals during playback. If the tape has nonuniform tension, if it does not pass the heads with a stable position or if the mechanical tape-head contact is not satisfactory, the phase will fluctuate. Another check can be performed by measuring the phase between a signal being recorded and its instantaneous reproduction. The tape transport delay may equal several times  $360^\circ$  phase shift, but the frequency can be adjusted to give zero mean indication. This method will indicate the stability of the forces acting on the tape. If wow and flutter are present, they will also contribute to the total error. Therefore the method is well suited to fast checks on the function of the entire mechanical system during normal transport conditions. Both in this, and the former case, the chosen frequency will determine the resolution of the measurement.

## MODULATION NOISE

A special source of distortion in tape recorders is found if the tape exhibits small rapid oscillations when passing the heads. Such vibrations will create sidebands to a pure tone recorded on a tape. The presence of this kind of imperfection is very quickly discovered when using a Heterodyne Analyzer Type 2010. This instrument has very narrow filters and furthermore provides frequency marker outputs which automatically calibrate the paper when used with the Level Recorder.

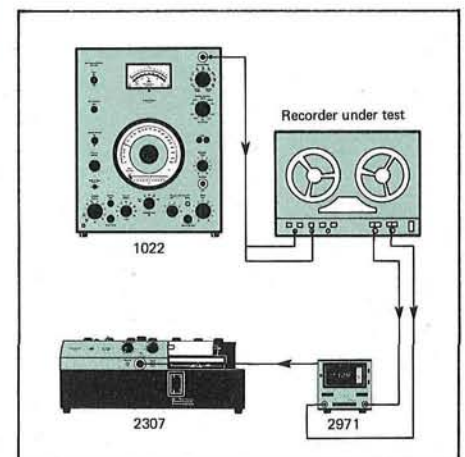





# Frequency Response-Undesired Signals

With the present state of technology it is quite easy to construct both preamplifiers and power amplifiers which are much more perfect than the transducers most commonly used in an audio channel, at least as far as frequency, phase and distortion characteristics are concerned. This does not mean that these quantities should not be measured and quoted by manufacturers. However, the procedures to be followed and the instruments to be used when performing traditional measurements on amplifiers will not be mentioned here since they are all straight forward and should be well known.

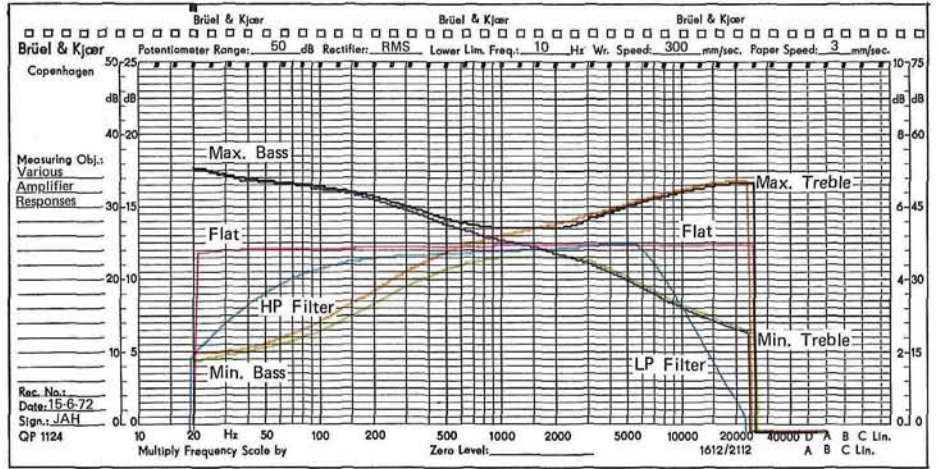

Tone control and filter influence on the frequency response of a modern amplifier.

## UNDESIED SIGNALS

A frequency analysis of the output signal with no input applied will disclose all the undesired components which will be added to a particular program. In multichannel amplifiers crosstalk may also be present. If the analysis is performed with the Heterodyne Analyzer Type 2010, the tracking BFO output may be applied to another channel and thus the measurement will cover hum, noise and crosstalk components simultaneously.

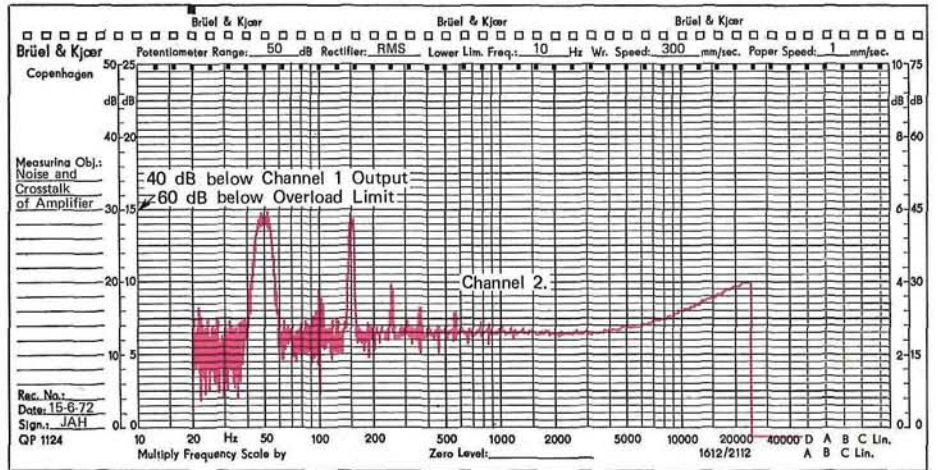

Combined analysis of undesired signals. The crosstalk is insignificant compared to the noise. The 10 Hz bandwidth of the Analyzer Type 2010 was utilized.

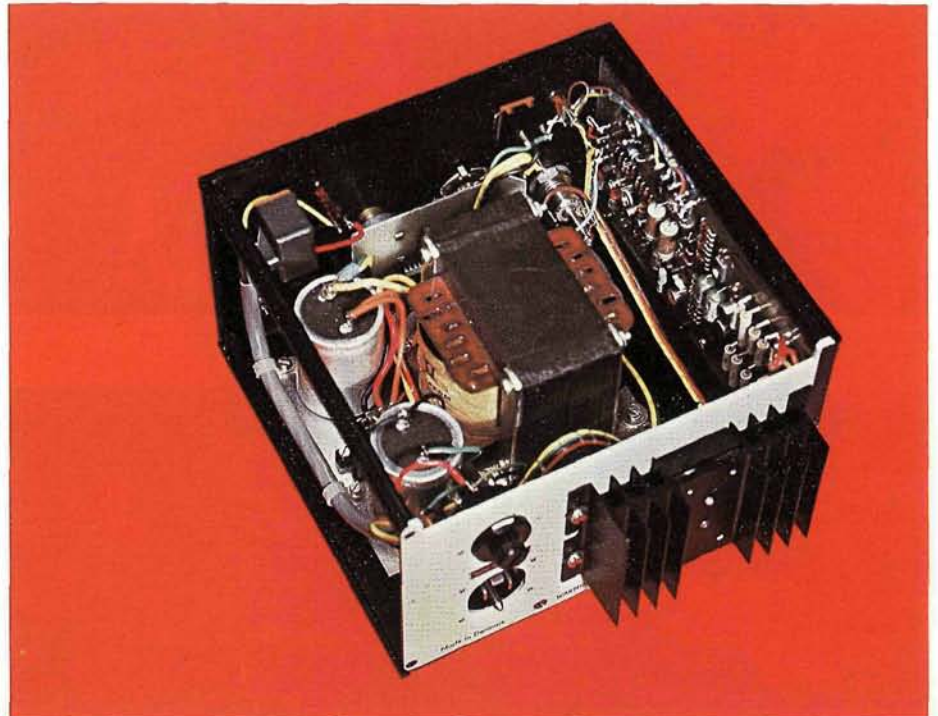
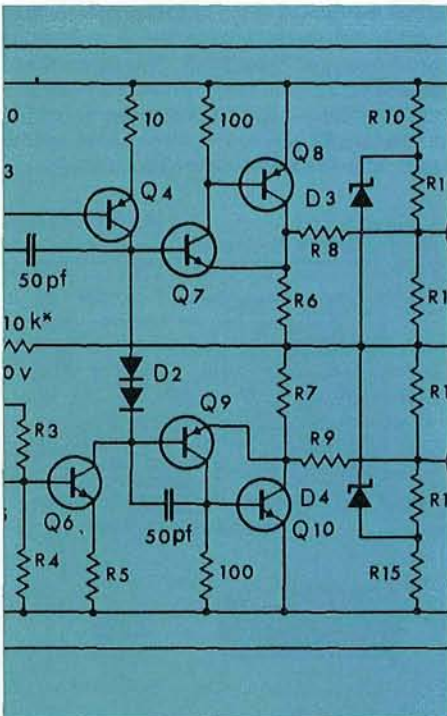



# System Check

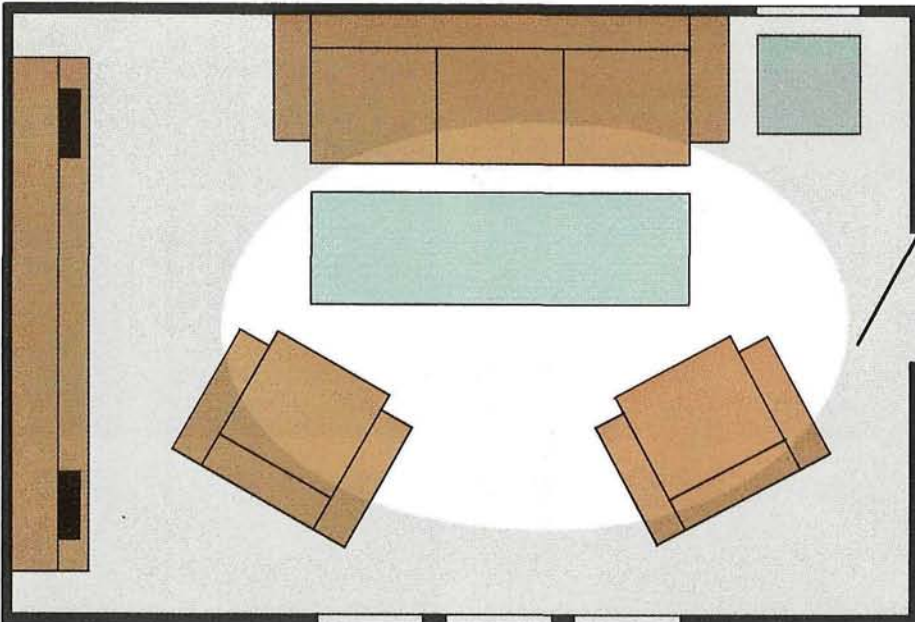

Even if the individual parts of a sound reproduction system are carefully designed, manufactured and tested, it may be a reasonable requirement to examine the response of the entire system when it is installed. This measurement has the very great advantage that the actual "listening room" is taken into account.

A well suited test signal is third octave pink-weighted random noise.

Test records are available with this type of signal. Its advantages are that small peaks or notches in the response are averaged out and that the noise bands contain the same mean energy, which in the ideal case should create a flat sound pressure curve. For the response measurement an inexpensive Sound Level Meter such as Type 2205 is placed at the listeners position and the meter is observed during the test. Due to the weighting network incorporated in this Sound Level Meter a correction must be performed in accordance with a curve supplied with the Meter.





In the previous sections a few of the existing electro-acoustic devices have been reviewed together with some measurement problems to which B & K instru-

ments may be applied with advantage. There are numerous other electro-acoustic devices on which measurements can be performed by the same instruments.

However, all of these devices have some properties in common with those discussed here and, therefore, the same measurement methods will apply.

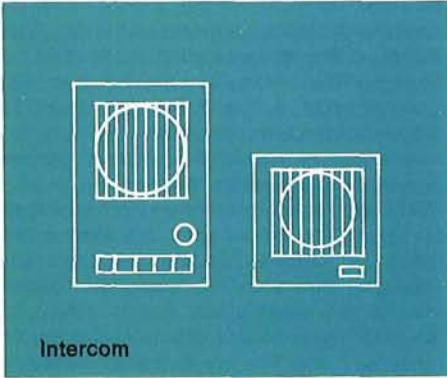

Intercom



Radio

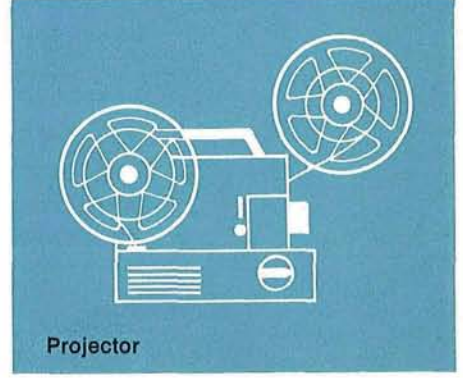

Projector



Foghorn

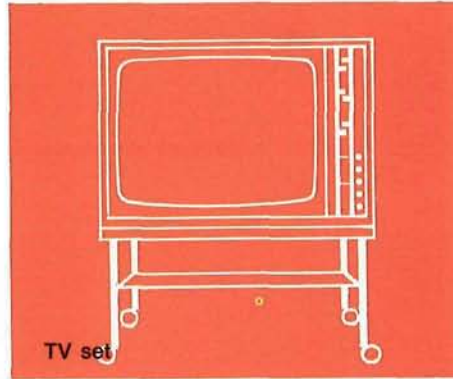

TV set

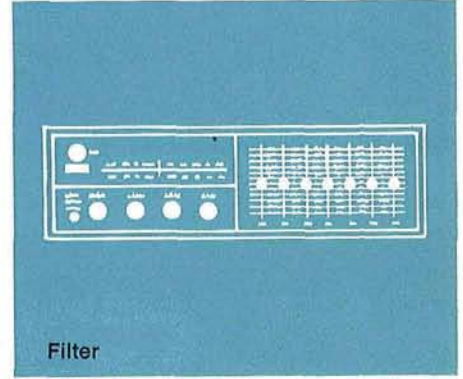

Filter

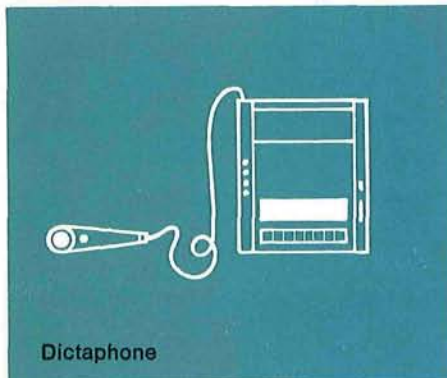

Dictaphone

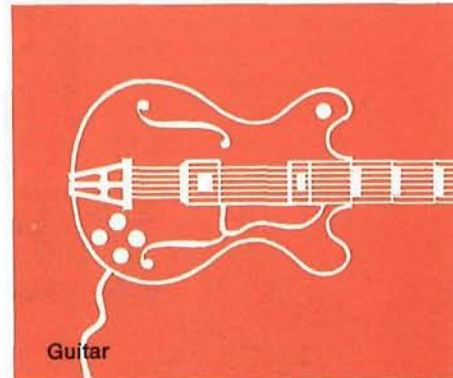

Guitar

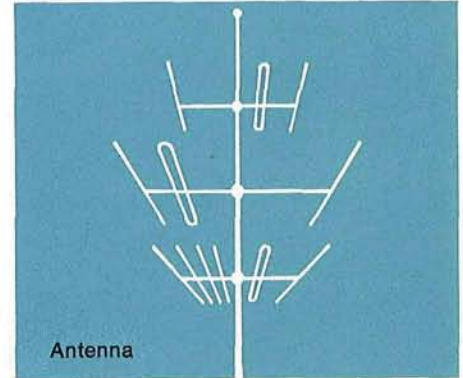

Antenna

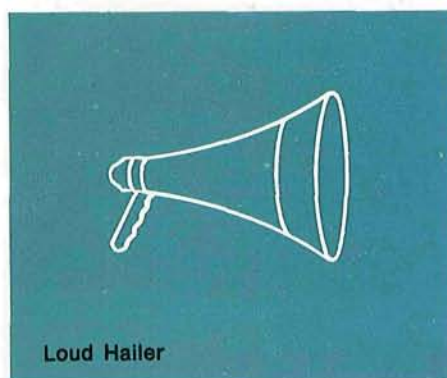

Loud Hailer



Mixing Console

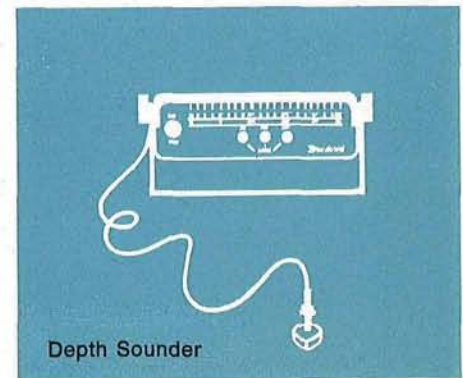

Depth Sounder



# Electroacoustic Standards



19

Organi- zation	Number	Date	Sta- tus <sup>*)</sup>	Short Description
IEC	94	1968	S	Tape recorders, recording and reproducing characteristics, speeds and dimensions of tape, position of tracks
IEC	200	1966	S	Loudspeakers, frequency response, polar plot, resonant frequency, power handling, test conditions, standard baffle
ANSI	S. 1.5	1963	S	Loudspeaker, impedance, frequency response, polar plot, distortion, efficiency, power handling, recommended
BS	1568	1960/66	S	Tape recording at 38, 19, 7 <sup>1</sup> / <sub>2</sub> and 3 <sup>3</sup> / <sub>4</sub> in/sec. Originally revised and extended 1966
BS	1927	1953	S	Loudspeaker, physical dimensions, impedance and resonant frequency
BS	1928	1965	S	Disc records, characteristics of reproducing equipment
BS	1988	1953	S	Wow and flutter, general recommendation for measurements
BS	2498	1945	S	Loudspeakers, frequency response, distortion, efficiency polar plot, impedance, transient response, conditions
BS	3499	1969	S	School music equipment, tape recorders, wow and flutter, frequency response, noise, distortion
BS	3499	1966	S	Amplifiers for musical instruments, function of tone controls, hum, noise
BS	3860	1965	S	Amplifiers, distortion, rated power, frequency response, intermodulation, hum and noise, methods and data presentation
DIN	45 500	NOV 1970	D	Disc reproducing equipment, wow and flutter, rumble, pick up frequency response, distortion, crosstalk
DIN	45 500	MAY 1971	D	Tape recorders, wow and flutter, frequency response, distortion, noise, crosstalk, erase damping
DIN	45 500	APR 1966	S	Microphones, frequency response, polar characteristic, distortion
DIN	45 500	AUG 1971	D	Amplifiers frequency range, distortion, intermodulation, crosstalk, noise, output power, damping ratio
DIN	45 500 sheet 1-3	FEB 1971	S	Loudspeakers, frequency response, power handling, distortion, music power
DIN	45 500	MAY 1971	S	Combined equipment, frequency response, crosstalk, distortion, intermodulation
DIN	45 507	OCT 1966	S	Sound recorders, measurement of wow and flutter
DIN	45 511 sheet 1-3	MAY 1971	S	Tapes 1/4", 1/2" and 1" width. Position of tracks
DIN	45 512 sheet 2	FEB 1969	D	Tapes, determination of electroacoustic properties.
DIN	45 513 sheet 1-6	1962-71	S	Test tapes for 1/4" tape at 76, 38, 19, 9 <sup>1</sup> / <sub>2</sub> and 4 <sup>3</sup> / <sub>4</sub> cm/sec.
DIN	45 519 sheet 2	MAY 1971	D	Tape, determination of print-through and nonuniformity of recorded flux
DIN	45 521	OCT 1963	S	Tape recorders, determination of crosstalk
DIN	45 542 to 45	FEB 1966	S	Test records, wow and flutter, rumble, crosstalk, tracking angle 33 and 45 rev/min.
DIN	45 573 sheet 1	JUL 1962	S	Loudspeakers, test conditions and methods for type test
DIN	45 573 sheet 2	JAN 1969	S	Loudspeakers, power handling and life test
DIN	45 575	MAY 1962	S	Loudspeakers, standard baffle for measurements

\*) S - Standard  
D - Draft

Above is given a list of the most relevant standards applied to electro acoustics. Many standards in the border area of this subject have been omitted and thus the list cannot be considered as being complete. Furthermore it is a known fact that several standard organizations have relevant subjects under consideration which may outdate the present survey in a relatively short period.





13-064

## Brüel & Kjær

DK-2850 NÆRUM, DENMARK · TELEPH.: (01) 80 05 00 · CABLE: BRUKJA, COPENHAGEN · TELEX: 15316