

Belmont

MODEL 6D121

SERIES A

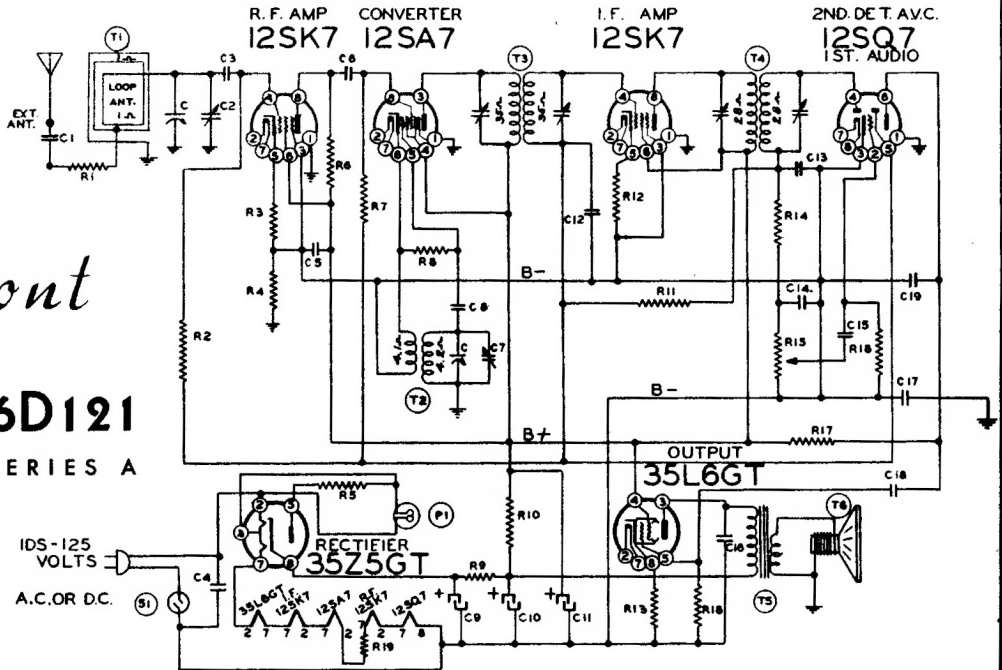

NOTE: On some sets slug tuned I.-F.s are used instead of trimmer tuned I.-F.s. 108-140H and 108-145 are trimmer tuned. B-13A-12023 and B-13B-12022 are slug tuned. The slug tuned I.-F.s are tuned from the top and bottom (secondary

on top, primary on bottom).

slug tuned I.-F.s cannot be used to substitute trimmer tuned I.-F.s but trimmer tuned I.-F.s can be used to substitute slug tuned I.-F.s.

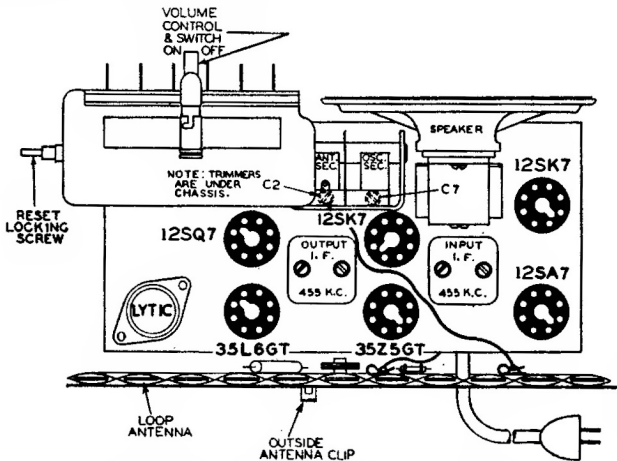

CHASSIS VIEW, SHOWING TUBE LOCATIONS
(See note above on I.-F.s)

Part No. Schematic Symbol Description

CONDENSERS

C-8D-10953	C17	.15 MFD x 400 volts.
C-8D-10778	C1, C15	.002 x 600 volts, +40%, -15%
C-8F3-12	C3	.470 mfd, mica, ±20%
C-8D-10760	C4	.1 x 400 volts, ±20%
C-8D-10775	C5	.25 x 200 volts, ±20%
C-8F3-8	C6, C8, C19	.001, mica, ±20%
11994 or A-8C-10077	C9, C10, C11	Electrolytic (for 50-60-cycle sets), 40 mfd. x 150 volts, 20 mfd. x 150 volts, 20 mfd. x 150 volts.
C-8D-10770	C12	.05 x 200 volts, ±20%
129161	C13, C14	Dual .0001, mica, ±10%
C-8D-10774	C16	.02 x 400 volts, ±20%
C-8D-10778	C18	.004 x 600 volts, ±20%

RESISTORS

C-9B1-13	R1	1000 ohms, 1/2 watt, ±20%
C-9B1-31	R2	1 megohm, 1/2 watt, ±20%
C-9B1-50	R3	100 ohms, 1/2 watt, ±10%
C-9B1-26	R4	150,000 ohms, 1/2 watt, ±20%
C-9B1-42	R5	22 ohms, 1/2 watt, ±10%
C-9B1-70	R6	4700 ohms, 1/2 watt, ±10%
C-9B1-25	R7	100,000 ohms, 1/2 watt, ±20%
C-9B1-28	R8, R14	47,000 ohms, 1/2 watt, ±20%
C-9B2-53	R9	180 ohms, 1 watt, ±10%
C-9B2-63	R10	1200 ohms, 1 watt, ±10%
C-9B1-34	R11	3.3 megohms, 1/2 watt, ±20%
C-9B1-52	R12, R13	150 ohms, 1/2 watt, ±10%
C-9B1-29	R16	470,000 ohms, 1/2 watt, ±20%
C-9B1-27	R17	220,000 ohms, 1/2 watt, ±20%
C-9B1-35	R18	4.7 megohms, 1/2 watt, ±20%
C-9B2-44	R19	33 ohms, 1 watt, ±10%

ALIGNMENT PROCEDURE

- No aligning adjustments should be attempted until all other possible causes of trouble have been checked.
- Chassis must be removed from cabinet for proper alignment. Slight adjustments of the oscillator and antenna circuits can be made, without removing the chassis, through two holes provided on the bottom of the cabinet. The two adjustment screws can be reached with a long insulated screwdriver.
- It is important that during alignment the loop antenna

- be maintained at the same distance from the chassis as when the chassis is installed in the cabinet.
- Turn volume control to maximum for all adjustments.
- Connect ground post of signal generator to B- of radio through a 0.1 mfd. condenser.
- Connect dummy antenna value in series with generator output lead.
- Connect output meter across primary of output transformer.

Band	Signal Generator Frequency Setting	Dummy Antenna	Connection to Radio	Tuning Condenser Setting	Adjust for Maximum Output (see chassis view)
I.F.	455 Kc.	0.1 mfd.	Grid of 12SA7	Rotor full open (plates out of mesh)	4 trimmers on input and output I.F. transformers (See note)
Broadcast	1650 Kc.	0.1 mfd.	Grid of 12SA7	Rotor full open (plates out of mesh)	Oscillator trimmer C7 on bottom of radio
	1400 Kc.	None	See note A	Set dial at 1400 Kc.	Antenna trimmer C2 on bottom of radio

Note A: Lay output lead of generator in back of loop antenna. Turn up generator output. Loop antenna will pick up