

DETROLA RADIO AND TELEVISION CORPORATION

DETROIT, MICHIGAN

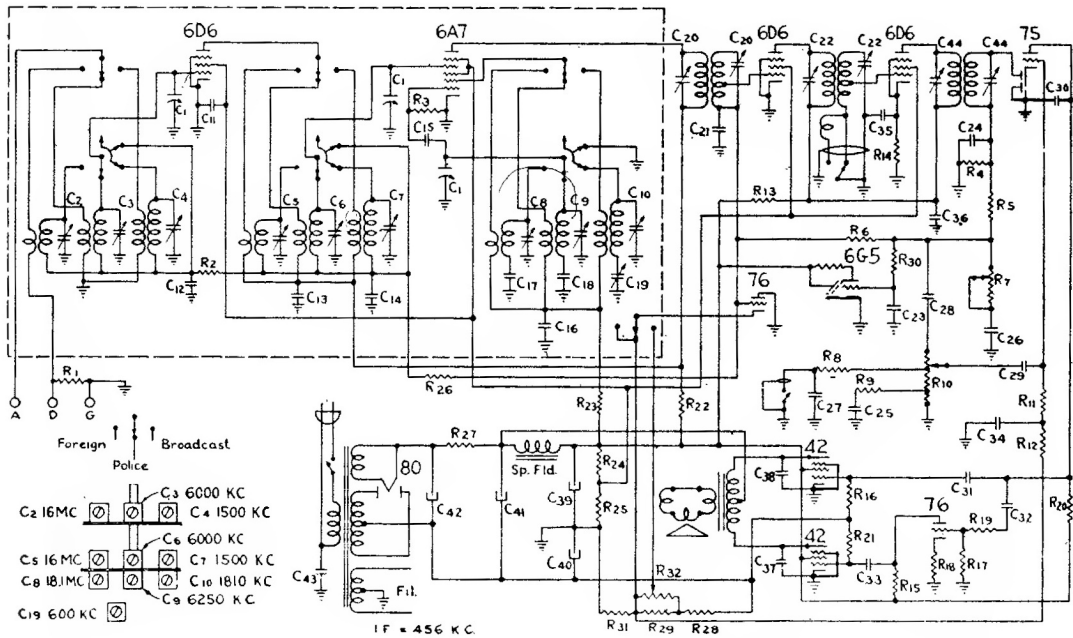

MODEL 165

Symbol Part No. Description

C1	3814	9-400 mmf Variable
C2,3,4	3822	2-35 triple trimmer
C5,6,7	3822	2-35 triple trimmer
C8,9,10	3822	2-35 triple trimmer
C11,12,13,4	572	.1-200 V.
C12,14,23	580	.05-200 V.
C13	575	.1-400 V.
C15,24	2780	50 mmf mica
C16,35	568	.01-400 V.
C17	2694	.005 5% tolerance
C18	2741	1330 mmf 5% tolerance
C19	2560	350 mmf variable padder
C20,22,44		IF Trimmer
C25	4072	.03-200 V.
C26	2695	.003-600 V.
C27	824	.002-600 V.
C28,29	576	.02-400 V.
C30	1286	250 mmf mica
C31,33	2600	.02-600 V.
C32,36	563	.05-400 V.
C37,38	3138	.001-800 V.
C39	3113	16 MF regulating
C40	3136	20 MF 25 V.
C41	3112	16 MF 450 V.

C42	3111	16 MF 500 V.
C43	3135	.003-800 V.
R1,5,15,26	603	100 M 1/3 W.
R2,3	631	50 M 1/3 W.
R4,16,21	615	500 M 1/3 W.
R6	2693	2 meg 1/3 W.
R7	3799	2 meg tone control
R8	2568	300 M 1/3 W.
R9,23	617	20 M 1/3 W.
R10	3800	3 meg volume control
R11,12	624	1 meg 1/3 W.
R13,14,22	2421	1 M 1/3 W.
R17	2880	100 M 1/3 W. 10 %
R18	614	5 M 1/3 W.
R19	2731	500 M 1/3 W. 10 %
R20	598	200 M 1/3 W.
R24	3805	7 M 3.5 W.
R25	3805	8 M 1.5 W.
R27	3809	100 ohms 2 W. 10 %
R28	3806	120 ohms 1.5 W. 10 %
R29	4111	85 ohms 1.0 W. 10 %
R30	2106	3 meg 1/3 W.
R31	3870	15 ohms .5 W. 10 %
R32	3801	2 M variable

Using 400 ohm resistor in series with generator, set band selector in center position, set generator to 5400 kc and adjust oscillator trimmer for top frequency. Set generator to 5000 kc, tune receiver to signal and adjust antenna trimmer.

Turn band selector to extreme clockwise position. Using 400 ohm resistor in series with generator, set oscillator top frequency for 15,750 kc—screw trimmer down tight, then unscrew to *second* peak. Set generator to 15,000 kc, tune receiver to signal and adjust antenna trimmer—Screw trimmer down tight, then unscrew to *first* peak, rocking the tuning condenser back and forth through the signal while the adjustment is being made. **Above procedure for alinement at 15,000 kc must be followed exactly to insure proper tracking.** A dead spot at about 12,000 kc will result if antenna and oscillator circuits are not set in proper relation to each other.