

International Detrola Corp.

FIVE-TUBE, BROADCAST BAND, AC  
Radio Chassis Model 558

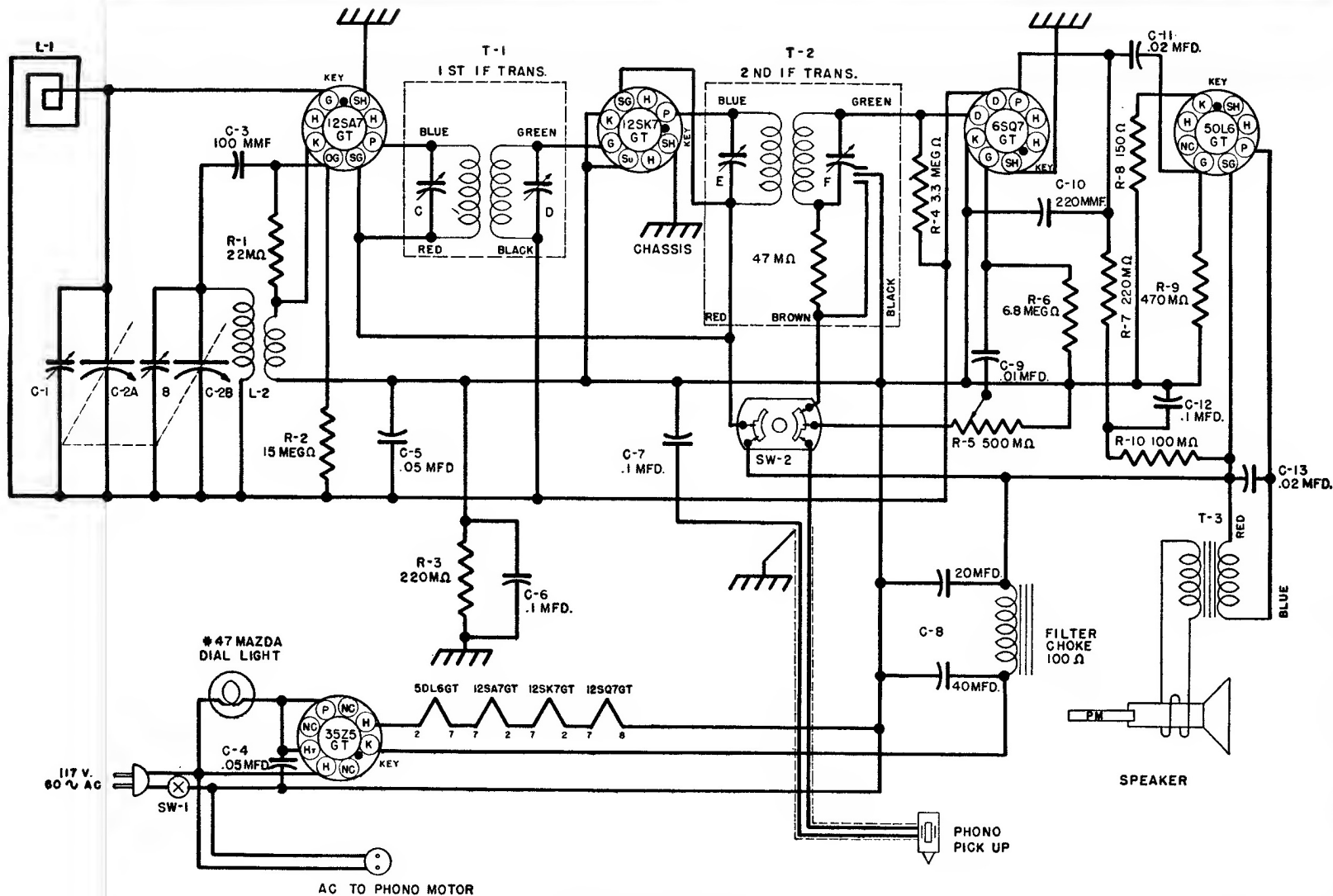

455 KC IF

ALL TUBE SOCKETS SHOWN FROM PIN END VIEW. ALL SWITCHES SHOWN IN COUNTERCLOCKWISE POSITION. SHAFT END VIEW

# International Detrola Corp.

# Radio Chassis Model 558

All DC voltages measured with a 1000 ohm-per-volt meter from ON-OFF switch (-B) to socket contact indicated. All AC voltages are measured from ON-OFF switch (-B) to socket contact indicated.

TUBE	POSITION	1	2	3	4	5	6	7	8
12SA7GT	Converter	0	36.3 AC	108	108	-5.6	0	23.8 AC	0
12SK7GT	IF Amplifier	0	11.4 AC	0	0	0	108	23.8 AC	108
12SQ7GT	Detector—1st Audio	0	0	0	0	0	43	11.4 AC	0
50L6GT	Power Output	0	85 AC	100	108	0	0	36.3 AC	7.3
35Z5GT	Rectifier	0	117 AC	112 AC	0	112 AC	0	85 AC	117

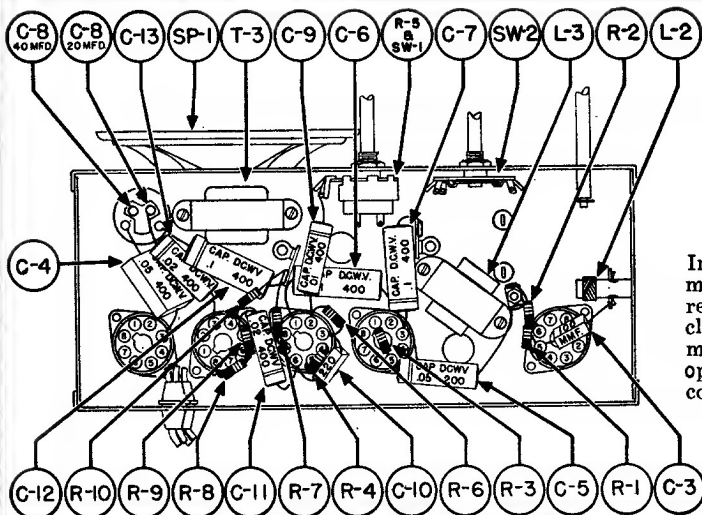

Volume Control full on. No signal.  
Line voltage 117 volts AC.

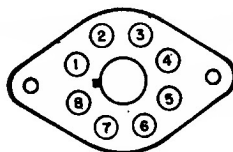

Intermediate Frequency and Oscillator adjustments may be made with the loop disconnected provided a resistor of 10,000 to 50,000 ohms is substituted to close the 12SA7GT grid circuit. The loop alignment must be done with the loop and chassis mounted in operating position in the cabinet. A single turn loosely coupled to loop may be substituted for RMA loop

## ALIGNMENT PROCEDURE

GENERATOR	CONNECTION AT RADIO	DUMMY ANTENNA	DIAL	TO TUNE TRIMMERS	REMARKS
IF 455 kc.	12SA7GT grid	.1 mfd.	HF end	IF trimmers C D E F	Tune to max.
1620 kc.	12SA7GT grid	RMA loop	HF end	Osc. trimmer B	Set limit of band
1400 kc.	Through loop*	RMA loop	1400 kc.	Ant. trimmer A	Tune to max.

\* Loop trimmer accessible through bottom of cabinet.

