

MODELS: FH-413 and FH-440

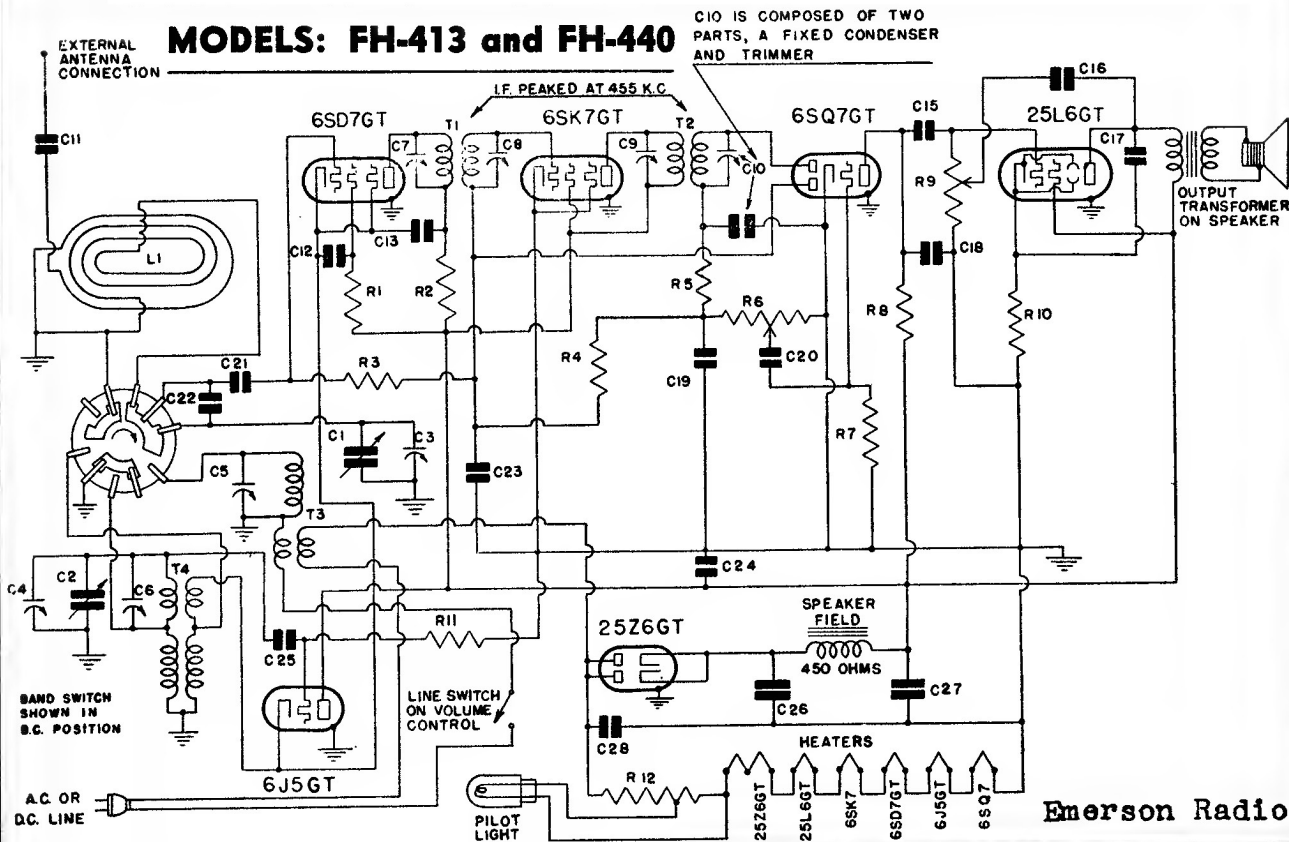

Tube	Plate	Screen	Cath
6SG7, 6SD7 or 7H7	92	63	0
6J5	102	—	0
6SK7 or 7A7	102	102	0
6SQ7 or 7B6	30	—	—
25L6	92	102	6.5

Alignment

Swing the variable condenser to the minimum capacity position. Feed 455 kc to the grid of the 6SD7 tube through a .01 mf condenser and adjust the four i-f trimmers for maximum response.

Note: The grid of the 6SD7 tube is the No. 4 pin.

Rotate the wave-band switch counter-clockwise to the short-wave position. Set the dial pointer at 12 megacycles and using a 400 ohm carbon resistor as a dummy antenna feed 12 megacycles from the generator to the external antenna lead emerging from the rear of the chassis. Adjust first the short-wave oscillator trimmer and then the short-wave antenna trimmer for maximum response.

Rotate the wave-band switch clockwise to the broadcast position. Set the dial pointer at 160 and feed 1600 kc from the signal generator into a loop of wire about 12 inches in diameter. Hold this radiating loop about 12 inches from the loop antenna and advance the signal generator until a deflection is obtained on the output meter. Adjust first the oscillator trimmer (rear section of the variable condenser) and then the antenna trimmer (front section of the variable condenser) for maximum response.

R1, R11	50,000 ohm ¼ watt carbon resistor.
R2	5,000 ohm ¼ watt carbon resistor
R3, R4	3 megohm ¼ watt carbon resistor.
R5	50,000 ohm ¼ watt carbon resistor
R6	Volume control: .5 megohm.
R7	10 megohm ¼ watt carbon resistor.
R8	500,000 ohm ¼ watt carbon resistor
R9	Tone control: 400,000 ohm
R10	140 ohm ½ watt wire-wound resistor
R12	Ballast resistor, 155 ohm
†C6	Trimmer, part of T4.
†C7, C8, C9	Trimmers, part of i-f transformers.
†C10	Trimmer and 0.0001 mf, mica condenser
C11, C20	0.002 mf, 600 volt tubular condenser
C12	0.02 mf, 200 volt tubular condenser
C13	0.05 mf, 200 volt tubular condenser.
C15, C17	0.02 mf, 400 volt tubular condenser
C16, C18, C21	0.00022 mf, mica condenser
C28	0.05 mf, 400 volt tubular condenser
C19, C25	0.00011 mf, mica condenser
C22	0.00046 mf, mica condenser
C23	0.1 mf, 200 volt tubular condenser
C24	0.01 mf, 400 volt tubular condenser
C26, C27	Dual 20 mf, 150 volt dry electrolytic