

# GENERAL ELECTRIC GE MODEL GD-500

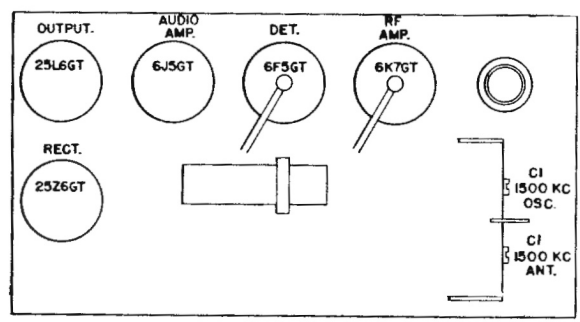
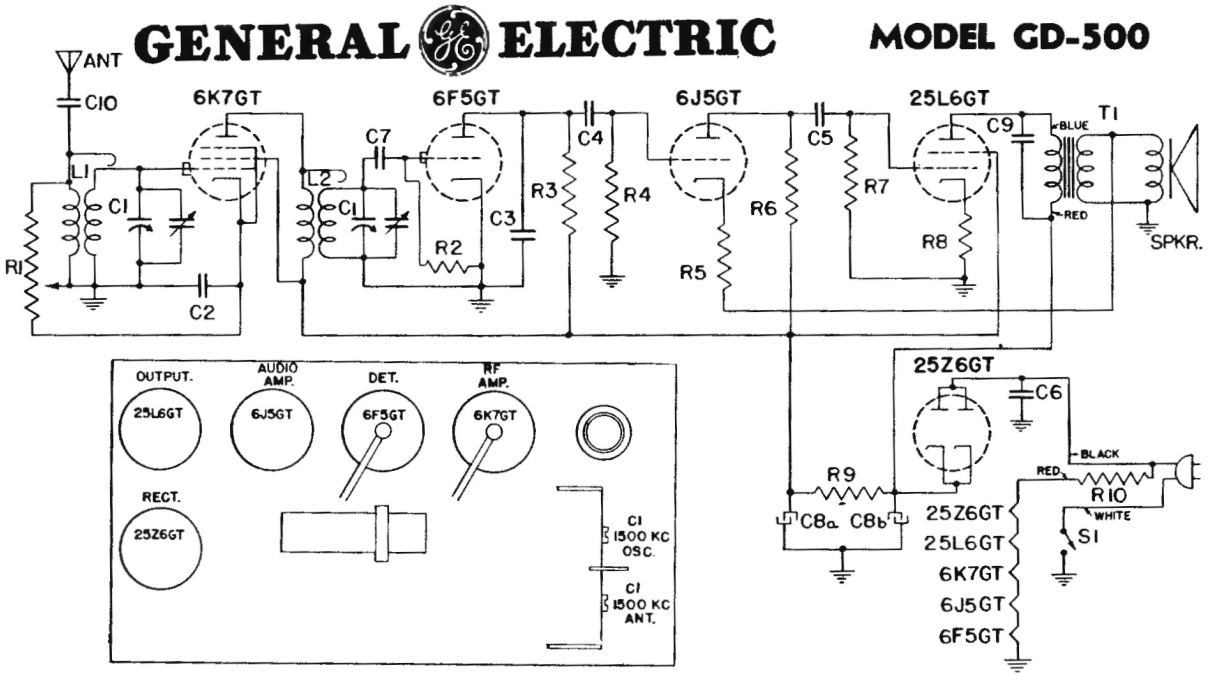

Symbol	Description	Symbol	Description
C-1	Tuning Condenser	C-9	.02 mfd., Paper Capacitor
C-2	.05 mfd., Paper Capacitor	C-10	.002 mfd., Paper Capacitor
C-3	.001 mfd., Paper Capacitor	R-1	30,000 ohm, Volume Control
C-4, -5	.005 mfd., Paper Capacitor	R-2	15 megohm, Carbon Resistor
C-6, -7	.01 mfd., Paper Capacitor	R-3, -4	470,000 ohm, Carbon Resistor
C-8a	15 mfd., Dry Electrolytic	R-5	3,300 ohm, Carbon Resistor
C-8b	30 mfd., Dry Electrolytic	R-6	100,000 ohm, Carbon Resistor
		R-7	470,000 ohm, Carbon Resistor
		R-8	150 ohm, Carbon Resistor
		R-9	4,700 ohm, Carbon Resistor
		R-10	162 ohm, Power Cord Resistor
		L-1	Antenna Coil
		L-2	RF Coil
		T-1	Output Transformer

## VOLTAGE CHART

Tube No.	6K7GT	6J5GT	6F5GT	25L6GT	25Z6GT
Plate to -B Volts	88	30 *	35 *	132	120. AC
Screen to -B Volts	88	...	....	88	....
Cathode to -B Volts	0	1.3	0	5.5	140
Filament Volts	6.4	6.3	6.2	25.0	25.0

Voltage measured when volume control is set to maximum.  
 Line Voltage—120 AC. No signal input.  
 \* Measured on 500-volt scale.  
 On DC, voltages should read approximately 10% lower.

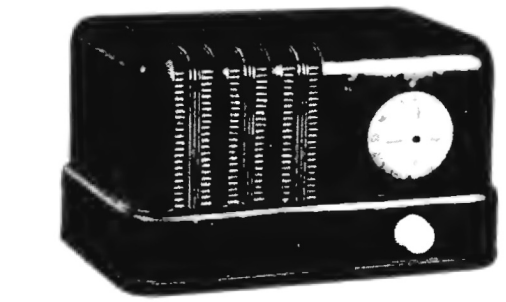

### Electrical Power Output

Undistorted.....1.4 watts  
 Maximum.....2.0 watts

### Loudspeaker—Permanent Magnet

Outside Cone Diameter.....4½ inches  
 Voice Coil Impedance (400 cycles).....3.5 ohms

### ALIGNMENT

Connect the high side of the signal generator through a 250 mmf. condenser to the antenna lead. The low side of the signal generator output should be connected to the receiver chassis through a .05 mfd. condenser. Connect a suitable output meter across the voice coil leads; then proceed as follows:

1. With gang condenser plates completely closed, the tuning mark should be over the last mark on the dial.
  2. Tune receiver to the 1500 KC point on the dial; then align trimmers on the gang condenser at 1500 KC for a maximum output meter reading.
- Precaution—One side of the power supply is connected to the chassis. Do not connect chassis to any external ground.