

Tuner Schematic Diagram

Hoffman

RADIO CORP.

MODEL B502 CHASSIS 113

TUNING RANGES:

Broadcast Band 535 Kc to 1650 Kc
 FM Band 88 Mc to 108 Mc

INTERMEDIATE FREQUENCIES:

Broadcast Band 455 Kc
 FM Band 10.7 Mc

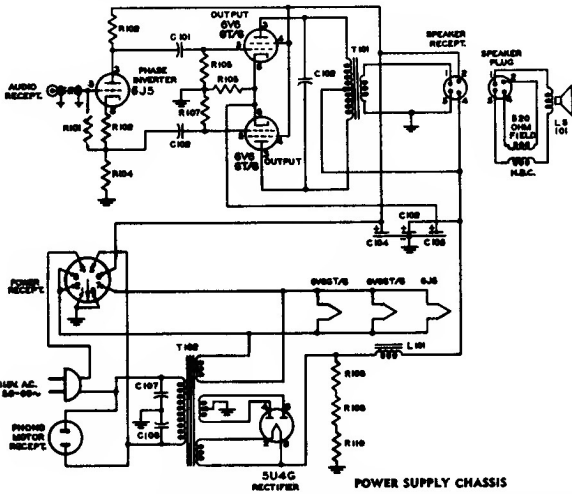

SYMBOL	DESCRIPTION	HOFFMAN NO.
C101, C102	.05 Mfd. 400 Volt Tub. Paper	4101
C103	470 Mmf. $\pm 20\%$ Mica	4003
C104, C105	20/20 Mfd. 450V. 20 Mfd. 25V. Electrolytic	4200
C106	.01 Mfd. 600 Volt, Metal Case	4105
C107, C106	.01 Mfd. 600 Volt, Metal Case	4105
R101	1 Meg. $\pm 20\%$ $\frac{1}{2}$ Watt	4513
R102, R104	47000 Ohm $\pm 10\%$ $\frac{1}{2}$ Watt	4559
R103	2200 Ohm $\pm 20\%$ $\frac{1}{2}$ Watt	4512
R105, R107	.22 Meg. $\pm 20\%$ $\frac{1}{2}$ Watt	4500
R106	220 Ohm $\pm 20\%$ 3 Watt W.W.	4706
R108, R109	10,000 Ohm $\pm 10\%$ 2 Watt	4503
R110	10,000 Ohm $\pm 10\%$ 2 Watt	4503
L101	Filter Choke	5118
T101	Audio Output Transformer	5108
T102	Power Transformer	5007
LS101	Speaker—12" Electrodynamic	9044

SYMBOL	DESCRIPTION	HOFFMAN NO.
C1, C9, C10, C28, C35, C37	100 Mmf. $\pm 10\%$ Ceramic	4012
C2, C18	1 - 8 Mmf. Trimmer	4315
C3, C4, C12, C14, C15, C16, C23, C4, C17, C22, C31	3 Sec. Variable with Split Stator	4408
C5, C25	.05 Mfd. 200 Volt Tub. Paper	4100
C7, C30, C34, C44, C51, C53	.02 Mfd. 400 Volt Tub. Paper	4003
C8, C13, C26	1.8 - 30 Mmf. Trimmer	4313
C11	500 Mmf. $\pm 5\%$ Silver Mica	4004
C19	50 Mmf. $\pm 2\%$ Ceramic	4023
C20	220 Mmf. $\pm 20\%$ Ceramic	4028
C21	110-560 Mmf. Trimmer	4301
C24	22 Mmf. $\pm 10\%$ Ceramic	4021
C27	5000 Mmf. (Min.) Ceramic	4029
C29	50 Mmf. $\pm 20\%$ Ceramic	4031
C32	20 Mfd. 450 Volt Electrolytic	4207
C33, C41	.001 Mfd. 600 Volt Tub. Paper	4104
C36	.02 Mfd. 400 Volt Tub. Paper	4106
C38	25 Mfd. 25 Volt Electrolytic	4205
C40, C46, C50, C52, C55	330 Mmf. $\pm 5\%$ Mica	4010
C42	650 Mmf. $\pm 5\%$ Mica	4011
C47	.005 Mfd. 600 Volt Tub. Paper	4102
C48	.002 Mfd. 600 Volt Tub. Paper	4118
C49	.5 Mfd. 200 Volt Tub. Paper	4110
C54	5 Mfd. 50 Volt Electrolytic	4209
C43	2300 Mmf. $\pm 5\%$ Mica	4006
R1	.27 Meg. $\pm 20\%$ $\frac{1}{2}$ Watt	4545
R2, R9, R15, R24	56 Ohm $\pm 10\%$ $\frac{1}{2}$ Watt	4561
R3, R10, R17, R30	33,000 Ohm $\pm 20\%$ 1 Watt	4556
R5, R7	.1 Meg. $\pm 20\%$ $\frac{1}{2}$ Watt	4511
R6, R12, R18, R33	1500 Ohm $\pm 20\%$ $\frac{1}{2}$ Watt	4534
R8	22 Ohm $\pm 20\%$ $\frac{1}{2}$ Watt	4560
R11, R35, R36	22,000 Ohm $\pm 20\%$ $\frac{1}{2}$ Watt	4501
R13	4700 Ohm $\pm 20\%$ 2 Watt	4551
R14	2.2 Meg. $\pm 20\%$ $\frac{1}{2}$ Watt	4502
R16, R32	1 Meg. $\pm 20\%$ $\frac{1}{2}$ Watt	4513
R19	.5 Meg. Pot. (Volumal)	4804
R20, R38	47,000 Ohm $\pm 20\%$ $\frac{1}{2}$ Watt	4506
R21	.68 Meg. $\pm 20\%$ $\frac{1}{2}$ Watt	4555
R22	4.7 Meg. $\pm 20\%$ $\frac{1}{2}$ Watt	4544
R23, R34	2200 Ohm $\pm 20\%$ $\frac{1}{2}$ Watt	4512
R25	.22 Meg. $\pm 20\%$ $\frac{1}{2}$ Watt	4500
R26	.12 Meg. $\pm 10\%$ $\frac{1}{2}$ Watt	4548
R27	15,000 Ohm $\pm 20\%$ $\frac{1}{2}$ Watt	4521
R28, R31	47,000 Ohm $\pm 20\%$ $\frac{1}{2}$ Watt	4559
R29	22,000 Ohm $\pm 5\%$ $\frac{1}{2}$ Watt	4538
R37	120 Ohm $\pm 10\%$ $\frac{1}{2}$ Watt	4546
R39	25 Meg. Pot. With Switch (Treble)	4805
R40	50,000 Ohm Pot. (Bass)	4806
R41	.47 Meg. $\pm 20\%$ $\frac{1}{2}$ Watt	4506
R42, R45	390 Ohm $\pm 10\%$ $\frac{1}{2}$ Watt	4549
R43, R44	6600 Ohm $\pm 10\%$ $\frac{1}{2}$ Watt	4557
L1	Loop Antenna	5210
L2	Antenna Coil—Broadcast	5285
L3	Coil—F.M. Ant.	5253
L4, L9	Coil—R.F.	5254
L5	Coil—F.M. R.F.	5252
L6	Coil—F.M. Osc.	5251
L7	Coil—Fil. R.F.	5266
L8	Coil—B.C. Osc.	5263