

Model 400 is a 12 tube, 3 band receiver with all coils shielded. See Fig. 4, for coil location and information on trimmers and padding condensers for each band. The 6F5 is a bass boost stage. The 6J5G is a phase inverter with push-pull 6V6G's in the output. The schematic of the model 425 illustrated is the same for the RF and IF stages. A single type 80 rectifier is used.

Model 425 is a 14 tube set having 6L6G's in the output.

Models 400-A and 425-A have the same electrical circuits as the 400 and 425. These models employ the Howard motor automatic tuning feature by use of the reversible motor controlled by the commutator disc near the back of the set.

ADJUSTMENT OF HOWARD MOTOR AUTOMATIC

FIRST - Select and depress the push-button by number that will include the desired station according to frequency chart listing below:-

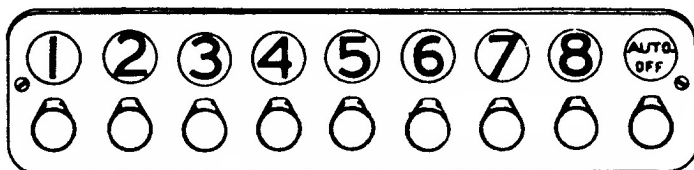

See next page-

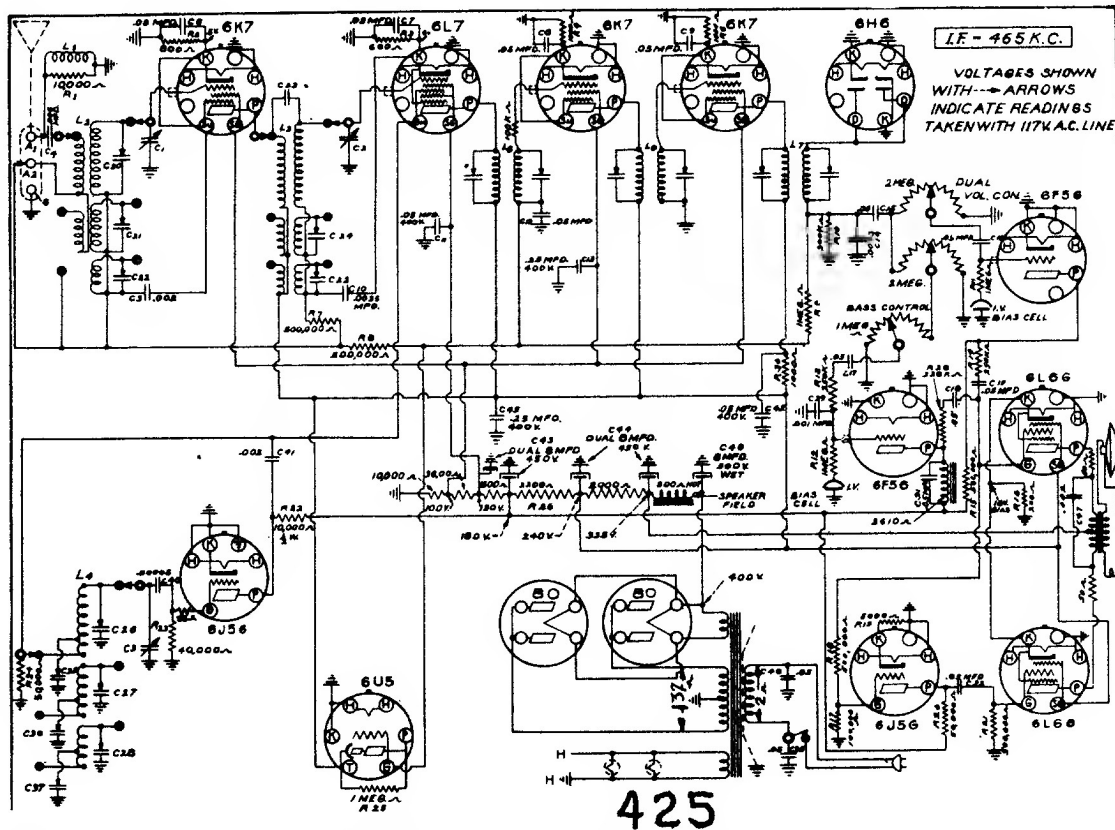

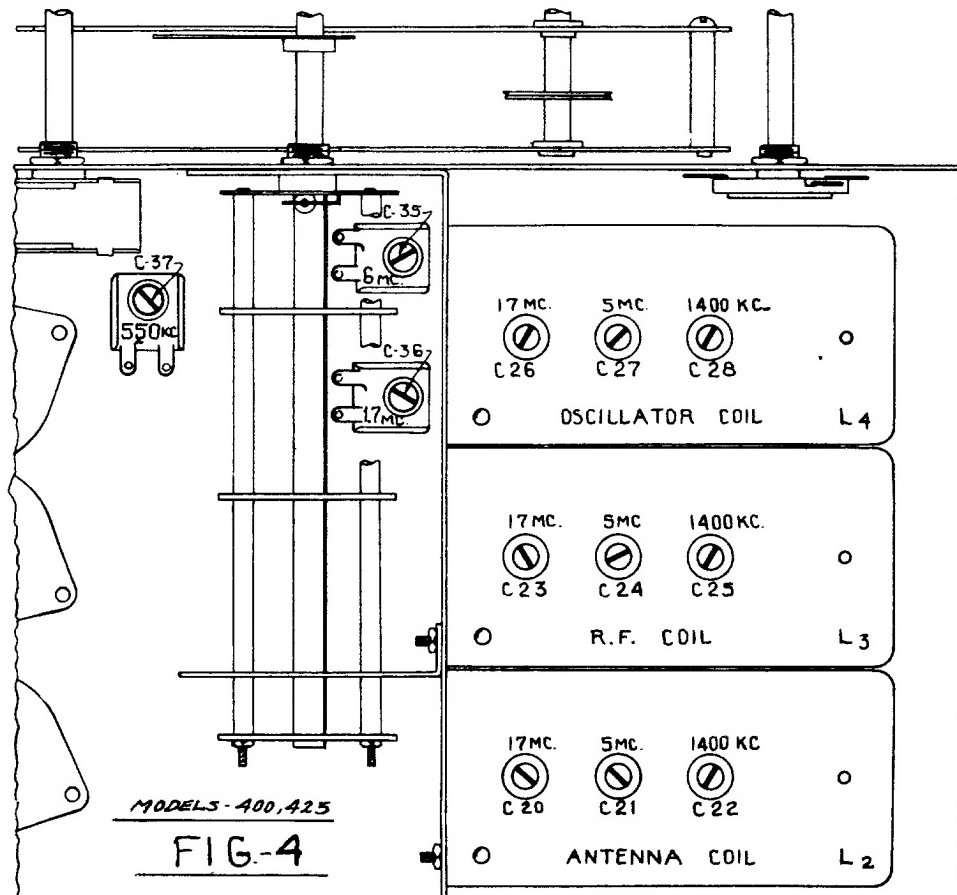

SECOND - Reach to back of chassis and turn muting switch to OFF position.

LOCATE THE SAME NUMBERED STATIONS CONTACTOR ON BACK OF TUNING CONDENSER THAT CORRESPONDS TO THE BUTTON DEPRESSED IN FIRST PARAGRAPH, AND SLIDE UNTIL THE DESIRED STATION IS TUNED IN.

With the muting switch in the OFF position the stations will be heard while moving the slide contactor. For silent tuning after all adjustments are made, turn switch to ON position.

THIRD - Remove station call letter tab from tab sheet and insert in place with finger tip in front of escutcheon plate over the number that was selected. Repeat above procedure for each of remaining buttons.

NOTE - When tuning the set by hand or if a remote cable is used the selector button AUTO-OFF must be depressed.

