

C₁, C₂-20, 30 MFD-150, 150 V.-NO. 47-266
 C₃, C₄-VARIABLE CONDENSER-NO. 63-270.
 VOLUME CONTROL AND SWITCH-NO. 69-281

HOWARD RADIO CO.
 MODEL 702

I. F.-465 K. C.

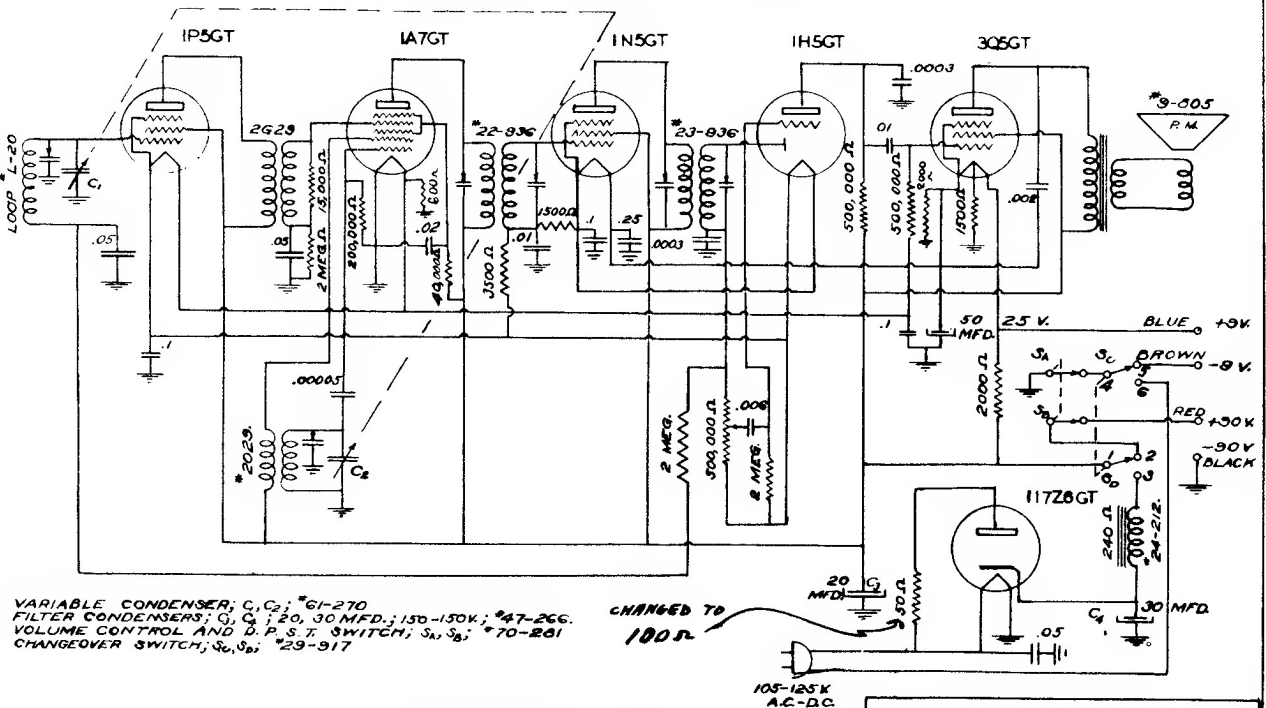

VARIABLE CONDENSER; C₁, C₂; *61-270
 FILTER CONDENSERS; C₃, C₄; 20, 30 MFD.; 150-150V.; *47-266.
 VOLUME CONTROL AND D. P. S. T. SWITCH; S₁, S₂; *70-281
 CHANGEOVER SWITCH; S₃, S₄; *29-917

CHANGED TO
 100 Ω

105-125 V.
 A.C.-D.C.

HOWARD RADIO CO.
 MODEL 14ACB

I. F. 465 K. C.

SWITCH SHOWN IN POSITION FOR
 BATTERY OPERATION. FOR A. C.
 OR D. C. OPERATION, SWITCH
 CONNECTS TERMINAL 4 TO 6
 AND 1 TO 3.