

MAJESTIC MODEL 360 RECEIVER

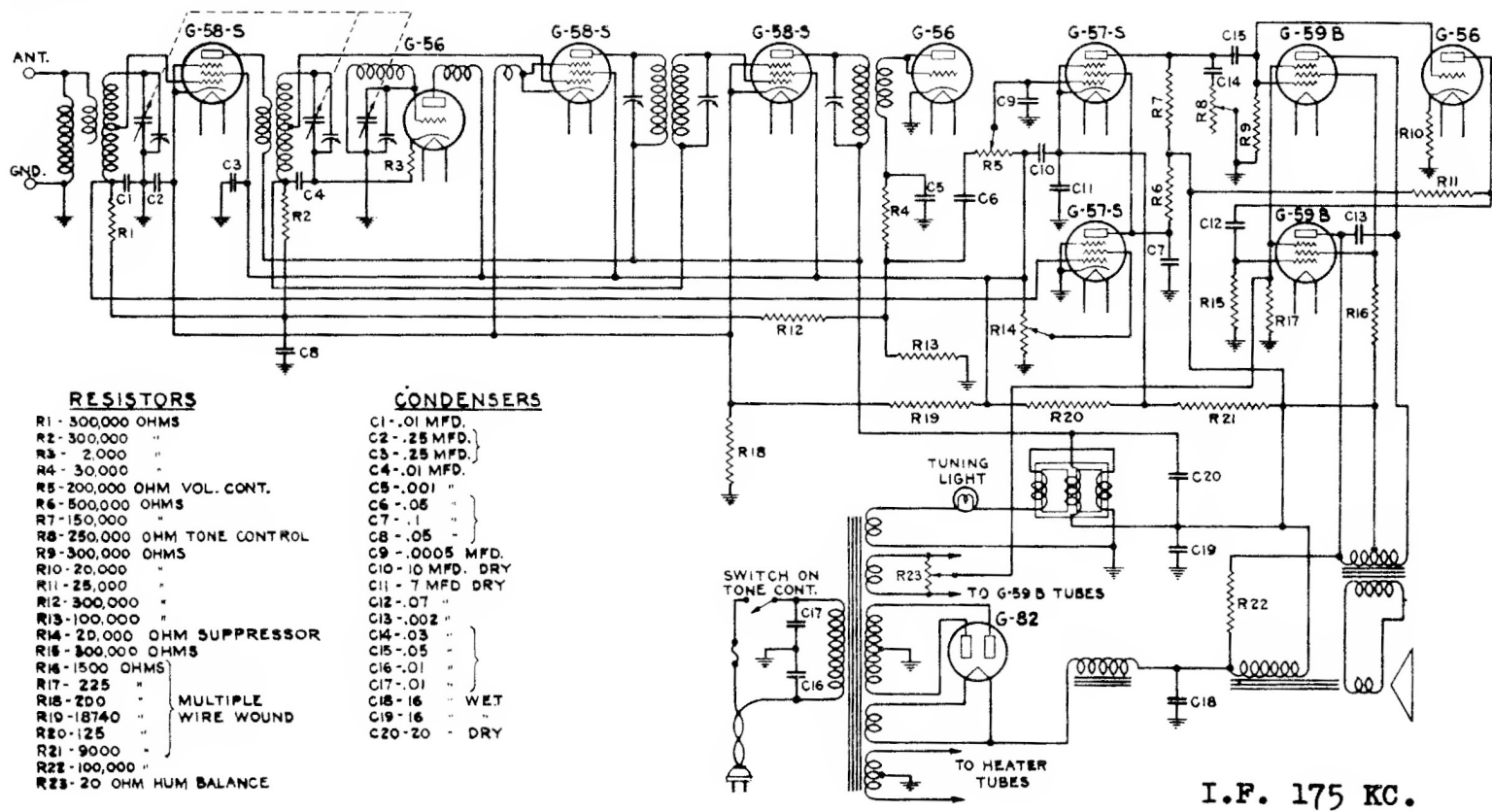

RESISTORS

- R1 - 500,000 OHMS
- R2 - 300,000 "
- R3 - 2,000 "
- R4 - 30,000 "
- R5 - 200,000 OHM VOL. CONT.
- R6 - 500,000 OHMS
- R7 - 150,000 "
- R8 - 250,000 OHM TONE CONTROL
- R9 - 300,000 OHMS
- R10 - 20,000 "
- R11 - 25,000 "
- R12 - 300,000 "
- R13 - 100,000 "
- R14 - 20,000 OHM SUPPRESSOR
- R15 - 300,000 OHMS
- R16 - 1500 OHMS
- R17 - 225 "
- R18 - 200 "
- R19 - 18740 " } MULTIPLE WIRE WOUND
- R20 - 125 "
- R21 - 9000 "
- R22 - 100,000 "
- R23 - 20 OHM HUM BALANCE

CONDENSERS

- C1 - .01 MFD.
- C2 - .25 MFD.
- C3 - .25 MFD.
- C4 - .01 MFD.
- C5 - .001 "
- C6 - .05 "
- C7 - .1 "
- C8 - .05 "
- C9 - .0005 MFD.
- C10 - 10 MFD. DRY
- C11 - 7 MFD DRY
- C12 - .07 "
- C13 - .002 "
- C14 - .03 "
- C15 - .05 "
- C16 - .01 "
- C17 - .01 "
- C18 - .16 " WET
- C19 - .16 "
- C20 - 20 " DRY

The Model 360 is an eleven tube chassis designed for single speaker operation in the Model 363 receiver. This chassis is very similar to the Model 300 chassis in that it provides Synchro-Silent Tuning, resistance coupled push-pull output, reactance dimmer action and automatic volume control. The tubes employed and their respective stages are as follows: G-58-S, R.F. amplifier; G-56, Oscillator; G-58-S, first detector; G-58-S, I.F. amplifier; G-56, second detector; G-57-S, first audio amplifier, G-57-S, suppressor; G-56, phase rotator; two G-59-B push-pull output and G-82 rectifier.