

TUBE	PLATE	SCREEN	PLUS FIL.	MINUS F.
1LN5 (V1)	100	100	2.5	1.4
1LC6 (V2)	100	50 (pin 3)	4	2.5
1LN5 (V3)	55	100	5.1	4
1LN5 (V4)	100	100	6.2	5.1
1LM4 (V5)	60	40 (pin 5)	1.4	0
25L6 (V6)	110	115	25 A.C.	0

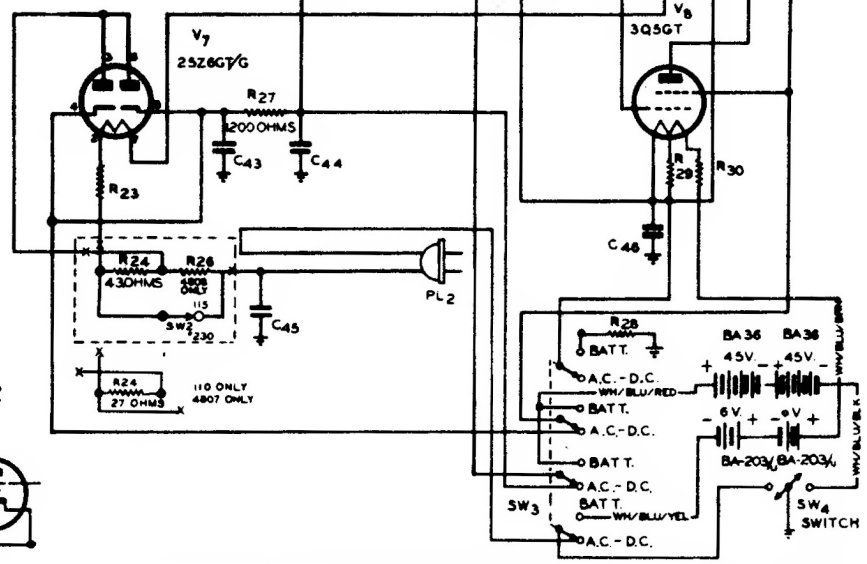
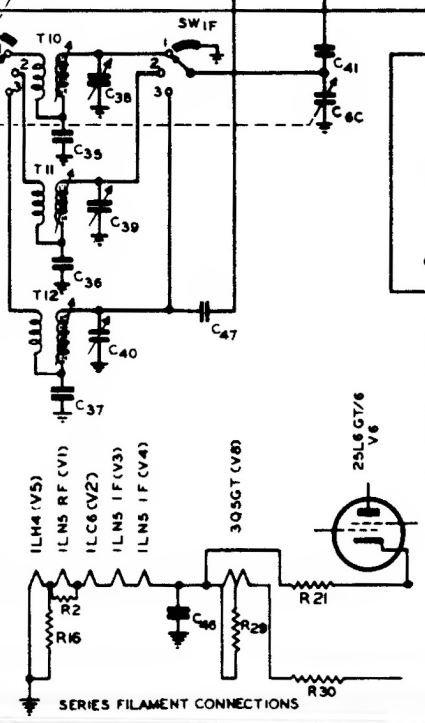

MODELS G1-426, G1-426Y
CHASSIS 4807, 4808

Majestic

Before aligning, make sure that the dial pointer is exactly horizontal when the tuning condenser is closed (plates fully meshed). While aligning the receiver, turn the volume control full on and keep the signal generator output as low as possible, to prevent AVC action and false readings.

Band-switch positions are extreme right for Broadcast, center for 3.6 to 8.5 mc., extreme left for 8.5 to 19 mc.

STEP	DUMMY ANT.	TEST. OSC. CONNECTION	TEST. OSC. FREQUENCY	RECEIVER BANDSWITCH	RECEIVER DIAL	ADJUST IN ORDER SHOWN	NOTES
1	.01 mfd	1LC6 grid (pin 6)	455 KC.	Right	Any Quiet Spot	T8, T7	#1
2	200 mmfd	ANT. post	600 KC.	Right	.6	"C"	#2
3	200 mmfd	ANT. post	1400 KC.	Right	1.4	Osc. Trimmer	
4	200 mmfd	ANT. post	1400 KC.	Right	1.4	R.F. Trimmer Ant. Trimmer	#3
5	400 ohms	ANT. post	4 MC.	Center	4	"B"	#2
6	400 ohms	ANT. post	8 MC.	Center	8	Osc. Trimmer	#4
7	400 ohms	ANT. post	8 MC.	Center	8	R.F. Trimmer Ant. Trimmer	
8	400 ohms	ANT. post	9 MC.	Left	9	"A"	#2
9	400 ohms	ANT. post	18 MC.	Left	18	Osc. Trimmer	#4
10	400 ohms	ANT. post	18 MC.	Left	18	R.F. Trimmer Ant. Trimmer	

NOTE #1 - Ground oscillator grid (1LC6 pin 4) while adjusting I.F. transformers.

NOTE #2 - "Rock" tuning gang while making this adjustment.

NOTE #3 - Carefully repeat steps 1 through 4.

NOTE #4 - When making short wave oscillator adjustments, take great care to see that alignment is not made on the image. When the trimmer is correctly adjusted, a weaker peak will be noticed at a receiver dial adjustment which is 910 KC lower than the aligning frequency.

Majestic

MODELS G1-426, G1-426Y
CHASSIS 4807, 4808

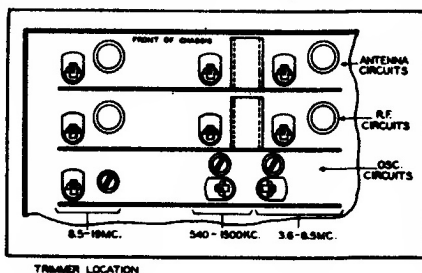
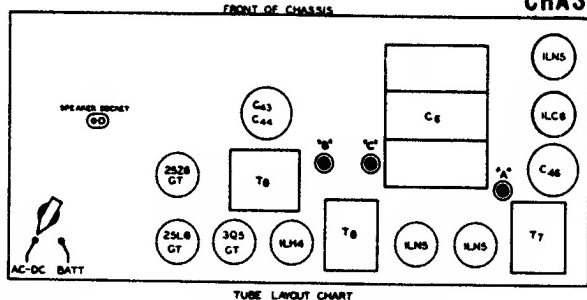

ITEM	DESCRIPTION
C1, C28, C30, C48	.006 mfd +20% 600 v molded paper
C2, C8	.05 mfd +20% -10% 200 v molded paper
C3, C9, C10, C38, C39, C40	Ceramic Trimmer 7-35 mmfd
C4, C5, C11	Ceramic Trimmer 34-72 mmfd
C6A, C6B, C6C	Variable, 3 gang
C7	15 mmfd +20% 500 v fixed ceramic
C12, C13, C21, C25, C31, C49	.1 mfd +40% -10% 400 v molded paper
C14	.0022 mfd 10% 500 v mica
C15	150 mmfd 5% 500 v mica
C16, C23	82 mmfd 5% 500 v mica
C17, C19	.02 mfd +40% -10% 200 v molded paper
C18	.01 mfd +20% -10% 400 v molded paper
C20	220 mmfd 20% 400 v fixed ceramic
C22	51 mmfd 5% 500 v mica
C24	.05 mfd +40% -10% 600 v molded paper
C26, C27, C41	100 mmfd 20% 500 v molded mica
C29	470 mmfd 20% 500 v molded paper
C33, C45	.01 mfd +40% -10% 600 v molded paper
C34, C43, C42, C44	40-40 mfd 250 v dual electrolytic
C35	430 mmfd 2% 500 v molded mica
C36	2200 mmfd 5% 500 v molded mica
C37	.003 mfd 5% 500 v molded mica
C46	1000 mfd 15 v electrolytic
J1	Phone Jack
L1	Line filter choke coil
L2	R.F. choke
LS1	Speaker, P.M. 6"
S01	Speaker receptacle
PL1	Speaker plug
R2	270 ohm 10% 1/4 watt carbon
R3, R8, R10	3.3 megohms 10% 1/4 watt carbon
R4	3.9 megohms 10% 1/4 watt carbon
R5	220,000 ohm 20% 1/4 watt carbon
R6	68,000 ohm 10% 1/4 watt carbon
R7, R13	1,000 ohm 20% 1/4 watt carbon
R9, R11	22,000 ohm 10% 1/4 watt carbon
R12, R15, R18	470,000 ohm 20% 1/4 watt carbon
R14	47,000 ohm 20% 1/4 watt carbon
R16, R29	330 ohm 10% 1/4 watt carbon
R17	1 megohm 20% variable with switch
R19	100,000 ohm 20% 1/4 watt carbon
R20	470,000 ohm 10% 1/4 watt carbon
R21	62 ohm 5% 1/4 watt carbon
R22	10 ohm 20% 1 watt carbon
R23	220 ohms 5% 30 watt wirewound
R24	43 ohm 5% 8 watt wirewound
R25	2200 ohm 10% 1/4 watt carbon
R26	260 ohm 5% 60 watt wirewound
R27	4700 ohm 10% 1 watt carbon
R28	820 ohm 10% 1/4 watt carbon
R30	27 ohm 10% 1/4 watt carbon
R31	12 megohms 10% 1/4 watt carbon