

Montgomery Ward Model 74WG-2705A

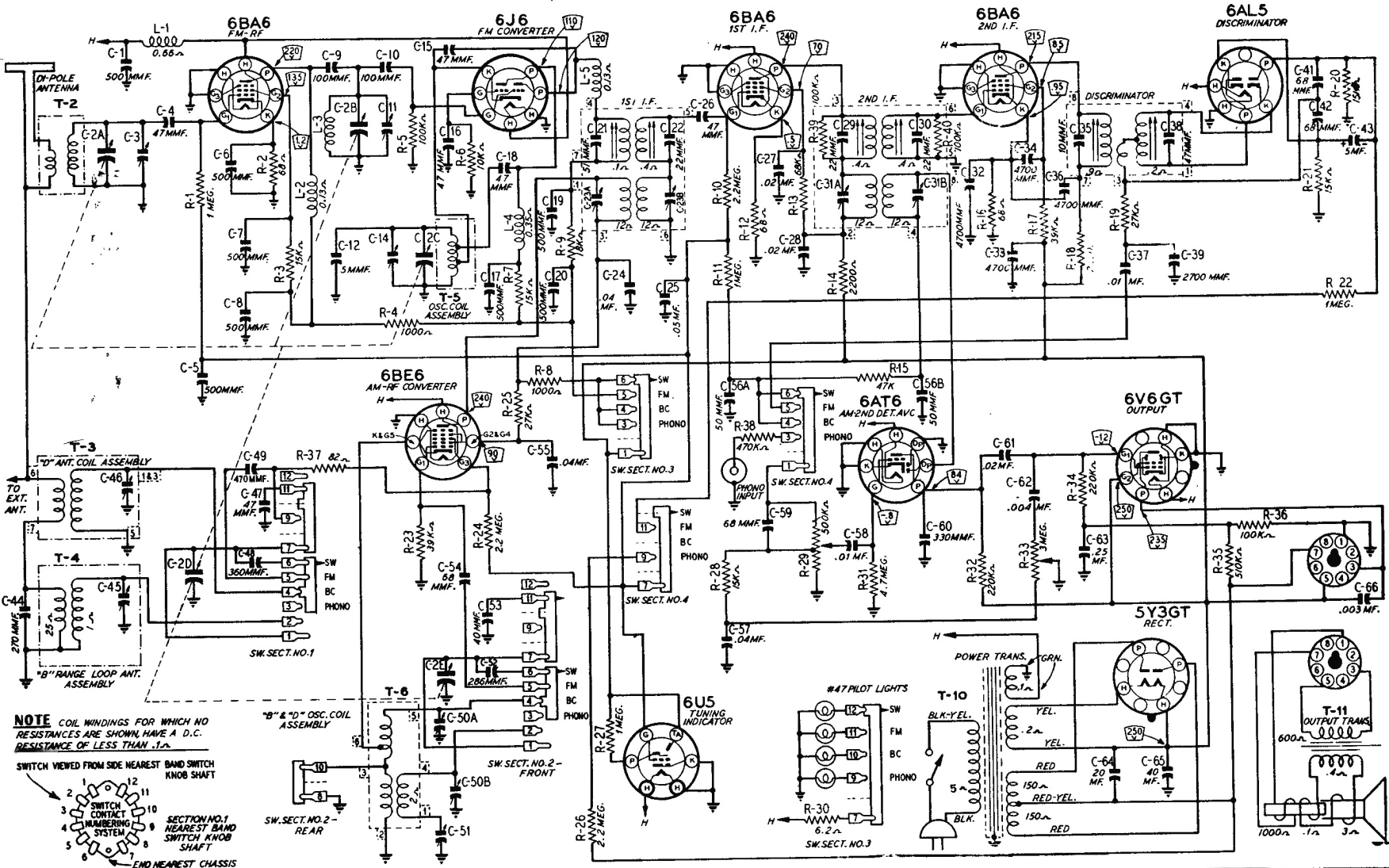

NOTE COIL WINDINGS FOR WHICH NO RESISTANCES ARE SHOWN, HAVE A D.C. RESISTANCE OF LESS THAN 1Ω.

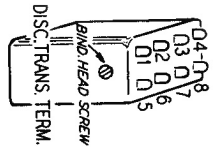
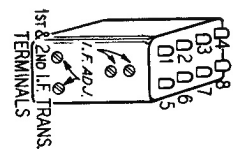
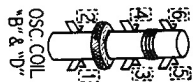
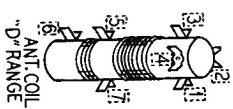
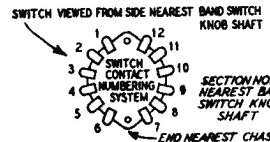

"B" & "D" OSC. COIL ASSEMBLY

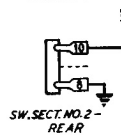

#47 PILOT LIGHTS

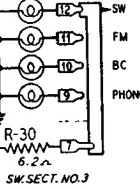

POWER TRANS. (GRN.)

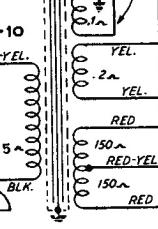

T-11 OUTPUT TRANS.

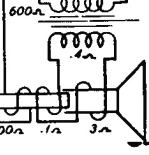

WARDS *Airline*

MODEL 74WG-2705A

SIGNAL GENERATOR		DUMMY ANTENNA	BAND SWITCH SETTING	CONDENSER SETTING	ADJUST TRIMMERS TO MAXIMUM	
FREQUENCY SETTING	CONNECTION AT RADIO					
I-F	455 kc.	6BE6 Pin 7	.1 mf	Broadcast	Rotor Fully Open	2nd I-F C-31B & C-31A 1st I-F C-23B & C-23A
Broadcast	1620 kc	External ant. lead	200 mmf	Broadcast	Rotor Fully Open	Oscillator C-50B
	1400 kc	External antenna lead	200 mmf	Broadcast	Turn Rotor to Max. Output Set painter to 1400 kc See Note A	Antenna C-45
	600 kc	External antenna lead	200 mmf	Broadcast	Turn Rotor to Max. Output and Rack See Note B	600 Kc padder C-51
Repeat above oscillator adjustments at 1620 and 600 KC until readjusting the oscillator Range B Trimmer C-50B causes no further improvement in output.						
Short Wave	15.5 MC	External antenna lead	400 ohm	Short Wave	Rotor Fully Open	Oscillator C-50A
	15 MC	External antenna lead	400 ohm	Short Wave	Turn Rotor to Max. Output	Antenna C-46
Reassemble chassis in cabinet						
Broadcast	1400 kc	External antenna lead	200 mmf	Broadcast	Turn Rotor to Max. Output	Antenna C-45

After each range is completed, repeat the procedure as a final check.
Note A—If the painter is not at 1400 KC on the dial, reset painter at the 1400 KC mark on the dial scale.

Note B—Turn the rotor back and forth and adjust the trimmer until the peak at greatest intensity is obtained.

Discriminator	10.7 MC Note B	6BA6 2nd I-F Pin 1 and Chassis	.01 mf	FM	Rotor to Full Open	Disc. Pri. ① Note A
	10.7 MC Note B	Same as above	.01 mf	FM	Same as above	Disc. Sec. Note C ②
	10.7 MC Note B	Same as above	.01 mf	FM	Same as above	Disc. Pri. ① Note A
	10.7 MC Note B	Same as above	.01 mf	FM	Same as above	Disc. Sec. Note C ②
I-F	10.7 MC	6BA6 1st I-F, Pin 1 and Chassis	.01 mf	FM	Same as above	2nd I-F Pri. Note A and D ③ 2nd I-F Sec. Note A and E ④
	10.7 MC	Connect to the FM-RF Gang Condenser terminal on underside of chassis	.01 mf	FM	Same as above	1st I-F Pri. ⑤ 1st I-F Sec. ⑥ Note A
Recheck I-F Adjustments in order given						
R-F & Osc.	108.4	Disconnect dipole and connect generator to dipole terminals with resistor in series	300 ohms	FM	Rotor to full open	Oscillator C-14
	104.5	Same as above	300 ohms	FM	Tune Rotor for Max. AVC voltage	R.F. C-11
	104.5	Same as above	300 ohms	FM	Same as above	Ant. C-3
Recheck R-F and Osc. Adjustments in order given						

Note A—Test Equipment connections are as given in the table. The zero center scale DC vacuum tube voltmeter is to be connected between chassis ground and the AVC line at the 1 megohm resistor R-22 and the band switch terminal (as shown in the illustration) for all adjustments except the discriminator secondary adjustment, for which see Note C.

Note B—A signal of .1 volt must be fed into the receiver for this adjustment.

Note C—Disconnect zero center DC vacuum tube voltmeter from AVC and reconnect to junction of R-19, C-37 and C-39 (See illustration). Adjust for zero voltage indication.

Note D—Before adjusting Pri. core connect 5000 ohm load resistor across the 2nd I.F. secondary terminals, (See illustration).

Note E—Disconnect 5000 ohm load resistor from secondary terminals and reconnect across the 2nd I.F. primary terminals, (See illustration).

