

PROCEDURE FOR MODELS 39-70 AND 39-75

Operations in Order	SIGNAL GENERATOR			RECEIVER		
	Output Connections to Receiver	Dummy Antenna Note A	Dial Setting	Dial Setting	Control Setting	Adjust Compensators
1	1A7G Grid	.1 mfd.	470 K. C.	580 K. C.	Vol. Max.	12A, 11B, 11A
2	Ant. (White)	225 mfd.	1550 K. C.	1550 K. C.	Vol. Max.	4B, 4A

PROCEDURE FOR MODEL 39-80

Operations in Order	SIGNAL GENERATOR			RECEIVER		
	Output Connections to Receiver	Dummy Antenna Note A	Dial Setting	Dial Setting	Control Setting	Adjust Compensators
1	1A7G Grid	.1 mfd.	470 K. C.	580 K. C.	Vol. Max.	13A, 12B, 12A
2	Ant. (White)	225 mfd.	1550 K. C.	1550 K. C.	Vol. Max.	4B, 4A

A—The "Dummy Antenna" consists of a condenser or resistor connected in series with the signal generator output lead (high side). Use the capacity or resistance as specified in each step of the above procedure.

B—DIAL CALIBRATION: In order to adjust the receiver correctly, the dial must be aligned to track properly with the tuning condenser.

Model 39-70 and 39-80—To adjust the dial proceed as follows: Turn the tuning condenser to maximum capacity (plates fully meshed). With the tuning condenser in this position, set the pointer horizontally across the dial.

Model 39-75—With the tuning condenser in the maximum capacity position (plates fully meshed), loosen the coupling screws connecting the push-button unit to the condenser. The pointer is then set on the extreme left edge of the index line (low frequency end of the scale) with the tuning condenser fully closed. The gang is then opened until the pointer is at the right edge of the index line. The push-button shaft is then turned counter-clockwise to its "stop." With the tuning condenser and push-button shaft in these positions tighten the coupling set screws.

C—The locations of the compensators in Models 39-70, 39-75 and 39-80 are shown in Figs. (1), (2) and (3) respectively.

Fig. 3. Compensator and Part Locations
Model 39-80, Code 121
Underside of Chassis

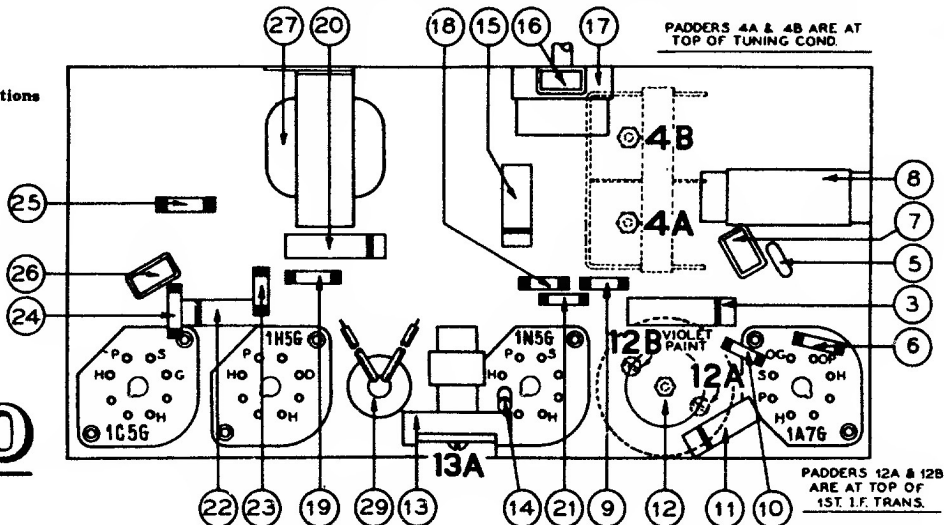

PHILCO

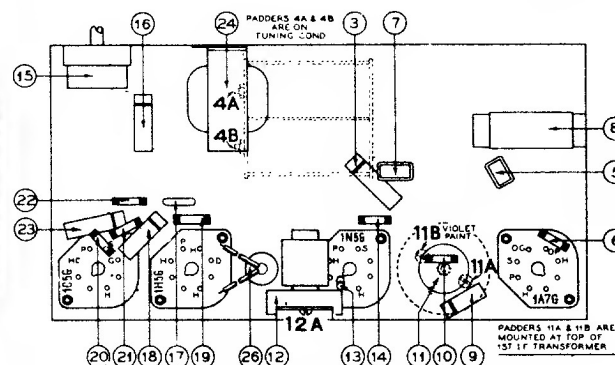

Fig. 1. Compensator and Part Locations
Model 39-70, Code 121

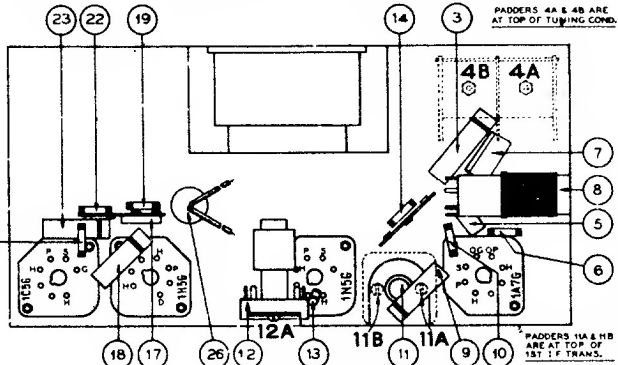

Fig. 2. Compensator and Part Locations
Model 39-75, Code 121-122
Underside of Chassis