

Models 41-250, 41-255; Code 121

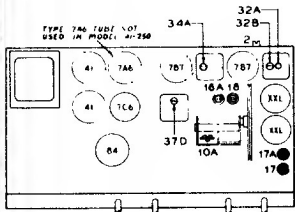

PHILCO

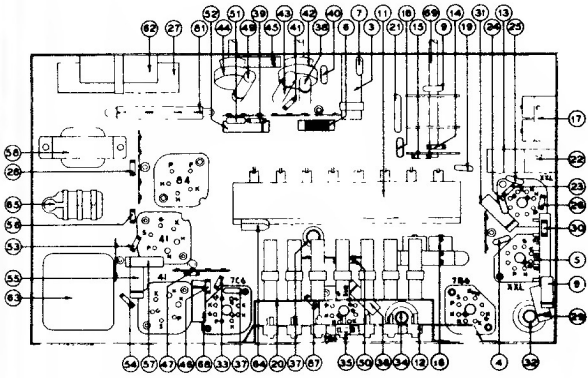

LOCATIONS OF PARTS AND TUBES
UNDERSIDE OF CHASSIS — MODEL 41-250

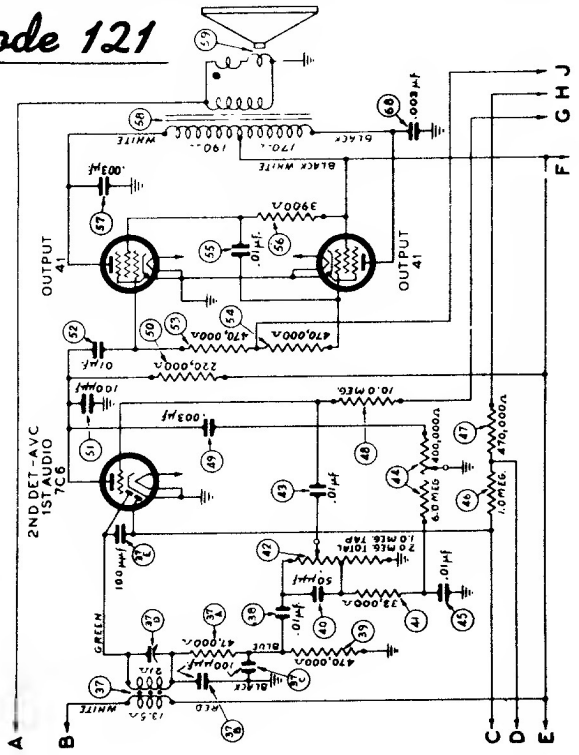

2ND DETECTOR AND AUDIO CIRCUIT
MODEL 41-250

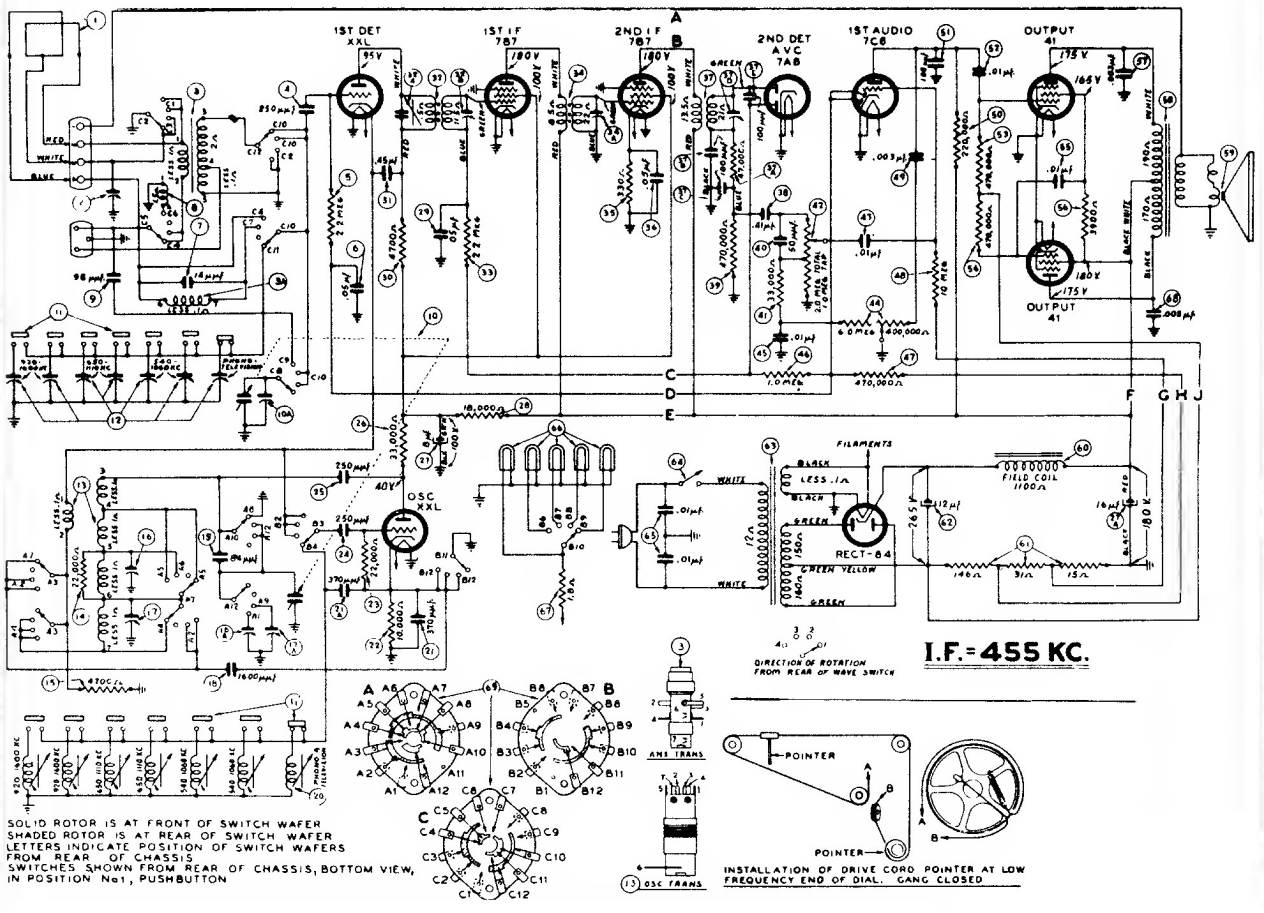

SOLID ROTOR IS AT FRONT OF SWITCH WAFER
SHADED ROTOR IS AT REAR OF SWITCH WAFER
LETTERS INDICATE POSITION OF SWITCH WAFERS
FROM REAR OF CHASSIS.
SWITCHES SHOWN FROM REAR OF CHASSIS, BOTTOM VIEW,
IN POSITION No. 1, PUSHBUTTON

I.F. = 455 KC.
DIRECTION OF ROTATION
FROM REAR OF WAVE SWITCH

