

SCHEMATIC DIAGRAM — MODELS 41-280, 41-285, 41-287, 41-290

The above diagram is the complete electrical circuit for the Models 41-285, 41-287. The same general circuit is also used in Models 41-280 and 41-290, with the exception of the 2nd detector, 1st audio A. V. C. wiring, Model 41-280 and the audio circuit, Model 41-290.

SIGNAL GENERATOR

Output Connections to Receiver	Dial Setting
High side to No. 4 terminal loop panel.	455 K. C.
Use loop on generator	1500 K. C.
Use loop on generator	580 K. C.
Use loop on generator	6 M. C.
Use loop on generator	12 M. C.

RECEIVER

Control Settings	Adjust Compensators in order
Vol. Max. Range Switch "S. W." Positions	32A, 32B 34A, 37D
Vol. Max. Range Switch Broadcast	16, 10
Vol. Max. Range Switch Broadcast	17

SPECIAL INSTRUCTIONS

Perform operation No. 2 again	Note A
Range Switch "Police"	Roll Tuning Condensers Note B
Range Switch "S. W."	17
16A	Note C
17A, 2	

NOTE A — DIAL CALIBRATION: In order to adjust the receiver correctly, the dial must be aligned to track properly with the tuning condenser. To adjust the dial, proceed as follows: With the tuning condenser closed (maximum capacity), set the dial pointer on the extreme left index line at the low frequency end of the broadcast scale. The arrangement of the drive cable in this position is shown in the schematic.

NOTE B — When adjusting the low frequency compensator of Range One (Broadcast) or the aerial padders of the high frequency tuning range; the receiver Tuning Condenser must be adjusted (rolled) as follows: First tune the compensator for maximum output, then vary the tuning condenser of the receiver for maximum output. Now turn the compensator slightly to the right or left and again vary the receiver tuning condenser for maximum output. This procedure of first

setting the compensator and then varying the tuning condenser is continued until maximum output reading is obtained.

NOTE C — To accurately adjust the high frequency oscillator compensator to the fundamental instead of the image signal, turn the oscillator compensator (17A) to the maximum capacity position (clockwise). From this position slowly turn the compensator counter-clockwise until a first peak is obtained on the output meter. Adjust the compensator for maximum output at this first peak.

If the above procedure is correctly performed, the image signal will be found (much weaker) by turning the receiver dial 910 K. C. above the frequency being used on any high frequency range.

The aerial padder (2) must be adjusted to maximum by rolling the tuning condenser. If two signal peaks occur when turning the padder, adjust to maximum output on the second signal peak from the tight position (screw all the way down) of the padder.

*Models 41-280, 41-285,
41-287, 41-290; Code 121*

PHILCO

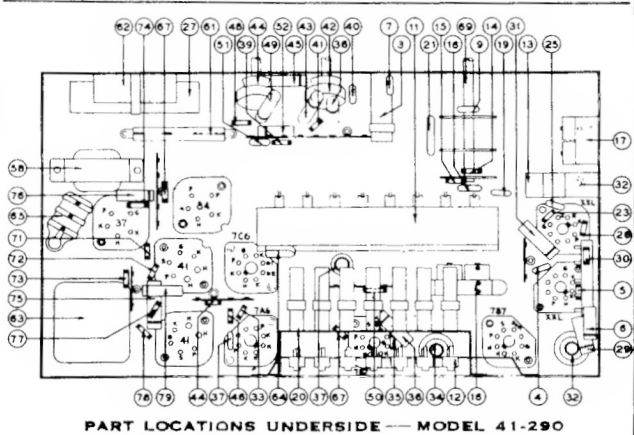

PART LOCATIONS UNDERSIDE — MODEL 41-290

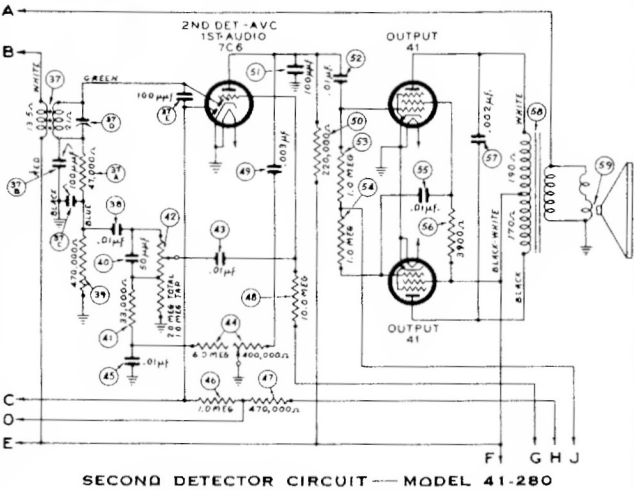

SECOND DETECTOR CIRCUIT — MODEL 41-280

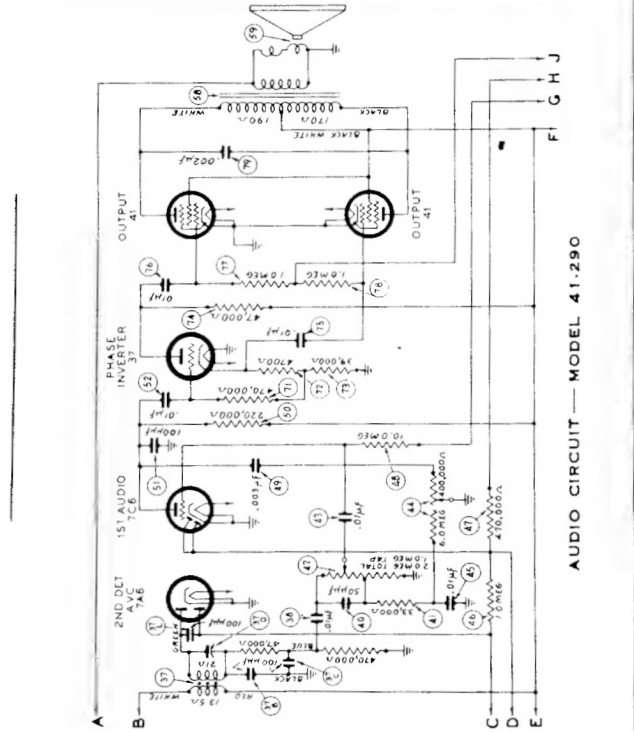

AUDIO CIRCUIT — MODEL 41-290