

PHILCO AUTO RADIO Model 920

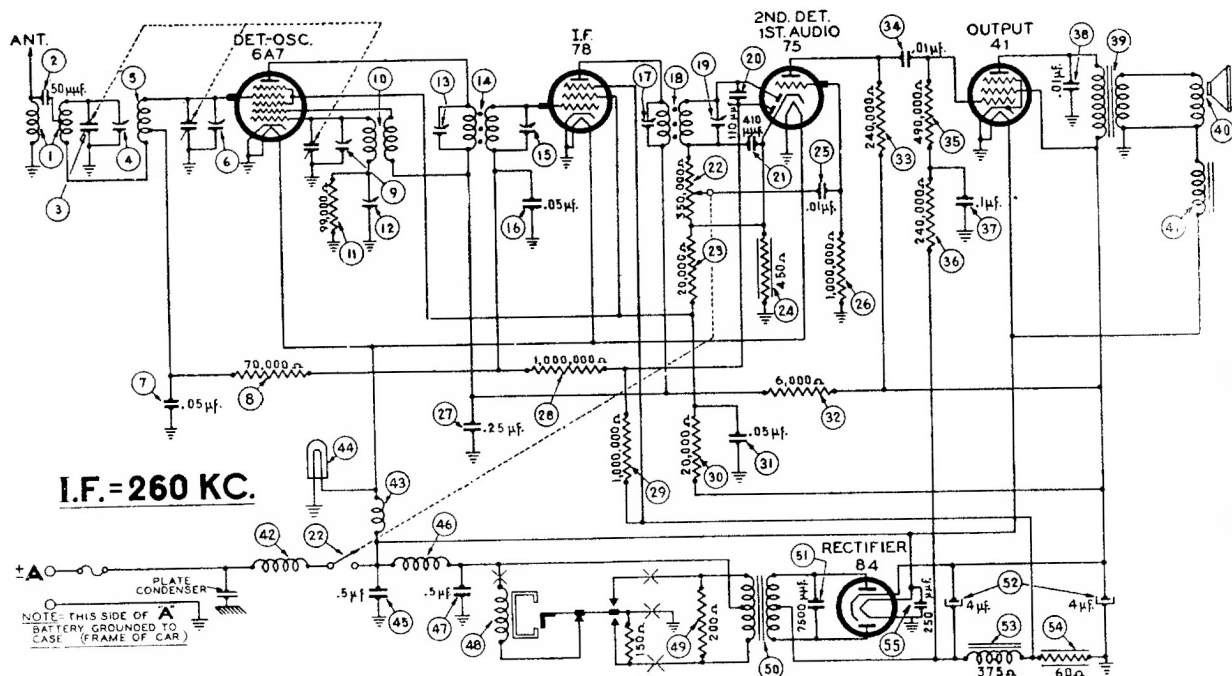

SIGNAL GENERATOR		DUMMY CAPACITY	SPECIAL INSTRUCTIONS	ADJUST PADDER
FREQUENCY	CONNECTION			
1	260 K. C. To grid of 6A7 Tube	.1 Mfd. Condenser in Series with Generator Lead	No Antenna Connection	17 18 13 15 17
2	1550 K. C. To Antenna Receptacle on Radio	50 Mmfd. See Note 1	Turn Tuning Condenser Plates Out of Mesh as Far as They Will Go.	9 6 6
3	580 K. C. To Antenna Receptacle on Radio	50 Mmfd. See Note 1	Set Tuning Condenser at 580 K. C.	Note 2 12
4	1550 K. C. To Antenna Receptacle on Radio	50 Mmfd. See Note 1	Turn Tuning Condenser Plates Out of Mesh as Far as They Will Go.	9
5	1400 K. C. To Antenna Receptacle on Radio	50 Mmfd. See Note 1	Set Tuning Condenser at 1400 K. C.	6 6 Note 3

Make all adjustments for maximum reading on the output meter.

- 1 — Connect the antenna lead, Part No. 41-3191, to the antenna receptacle in the radio. Connect a 50 Mmfd. Condenser in series between the signal generator and the antenna lead.
- 2 — Rock the tuning condenser while adjusting the low frequency paddler. Tune the condenser to the signal and adjust the paddler for maximum output. Rotate the tuning condenser back and forth slightly for maximum output. Then re-adjust the paddler for maximum output. Repeat this procedure until no further improvement is noticed.
- 3 — When the antenna stage adjustment is made with the Radio installed in the car, the Radio antenna lead must be connected to the car antenna in the usual manner. Connect the signal generator output lead to a wire placed near the car antenna but not connected to it.

I. F. TRANSFORMERS

