

APPROX. GAIN DATA

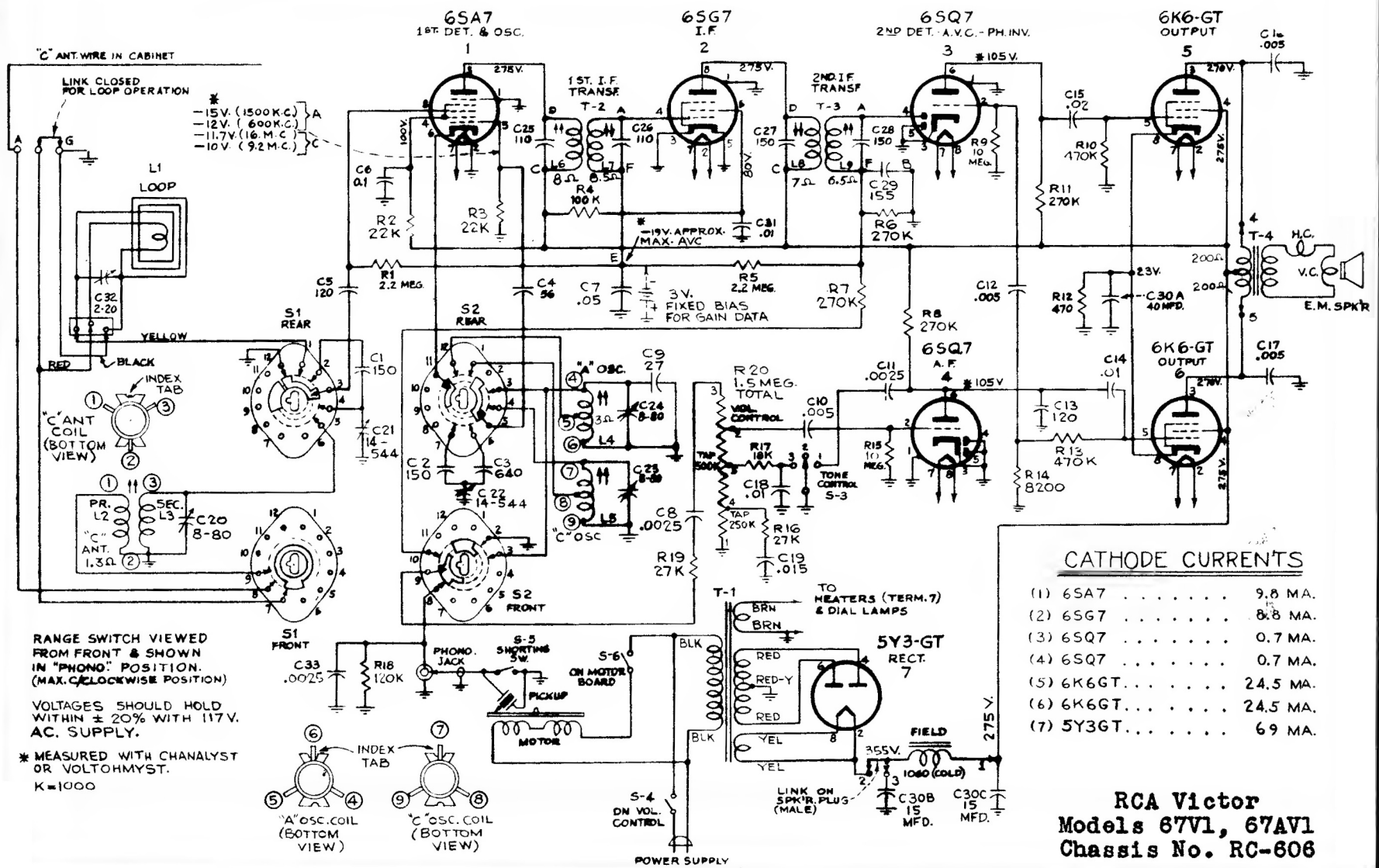
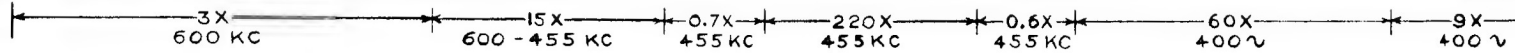

CATHODE CURRENTS

(1) 6SA7	9.8 MA.
(2) 6SG7	8.8 MA.
(3) 6SQ7	0.7 MA.
(4) 6SQ7	0.7 MA.
(5) 6K6GT	24.5 MA.
(6) 6K6GT	24.5 MA.
(7) 5Y3GT	69 MA.

RANGE SWITCH VIEWED FROM FRONT & SHOWN IN "PHONO" POSITION. (MAX. C/CLOCKWISE POSITION)

VOLTAGES SHOULD HOLD WITHIN $\pm 20\%$ WITH 117V. AC. SUPPLY.

* MEASURED WITH CHANALYST OR VOLTOHMYST.
K=1000

RCA Victor
Models 67V1, 67AV1
Chassis No. RC-606

RCA VICTOR

VICTROLA 67VI, 67AVI

Radio-Phonograph Combination

Chassis No. RC-606,

FOR AUTOMATIC CHANGER INFORMATION
REFER TO SERVICE DATA FOR MODEL 960260-1

Output Meter Alignment.—If this method is used, connect the meter across the voice coil, and turn the receiver volume control to maximum.

Test Oscillator.—For all alignment operations, connect the low side of the test-oscillator to the receiver chassis, and keep the oscillator output as low as possible to avoid a-v-c action

Calibration Scale.—The dial scale printed in this service note may be temporarily attached to the chassis for quick reference during alignment.

Using Printed Dial Scale.—

1. Cut out the printed dial scale, or, better still, make a tracing of the scale.
2. With gang at full mesh the pointer should be set to the second reference mark from the left hand end of the dial backing plate.
3. Place the printed dial scale or the tracing under the pointer so that the extreme left scale graduations coincide with the pointer. Use scotch tape to hold the dial scale in place.

Note.—It is not recommended that the glass dial scale in the cabinet be removed as an alignment reference. This glass dial scale is fastened to the bezel with sheet metal lugs bent over the scale to hold it in place. Removing the glass dial scale will necessitate bending the lugs, resulting in their weakening and subsequent breakage.

"C" Band Reception.—For best reception on "C" band with an outside antenna, adjust the trimmer-screw of C20 on the antenna coil. Turn screw carefully with an insulated screwdriver (RCA Stock No. 31031) while the receiver is tuned to a station in the 31-meter band. If returning to internal antenna at any time, close the link on the center terminal and readjust "C" band antenna trimmer C20 for best reception on 31-meter band.

For additional information, refer to booklet, "RCA Victor Receiver Alignment."

Steps	Connect high side of test oscillator to—	Tune test oscillator to—	Turn radio dial to—	Adjust the following for maximum peak output
1	6SQ7 grid in series with .01 mfd.	455 kc.	Broadcast Quiet Point at 550 kc. end of dial	L8, L9 (2nd I-F Trans.)
2	6SA7 grid in series with .01 mfd.			L8, L7 (1st I-F Trans.)
3	Yellow lead on loop in series with 200 mmfd. (link closed)	1,400 kc.	Broadcast 1400 kc.	C24 (osc.)
4		600 kc.	Broadcast 600 kc.	L4 (osc.) Rock gang
5		Repeat steps 3 and 4.		
6	Antenna terminal in series with 47 mmfd.	15.2 mc.	Short Wave 15.2 mc.	C23 (osc.) C20 (ant.)
7		9.5 mc.	Short Wave 9.5 mc.	L5 (osc.) L9 (ant.)
8		Repeat steps 6 and 7		
9	Install and connect chassis in cabinet with link closed. Tune in a radiated signal of 1400 kc. on broadcast band and peak C32 on loop.			

* Use minimum capacity peak if two can be obtained. Check for selection of correct peak by tuning the receiver to approximately 14.3 mc., where a weaker signal should be received.

Oscillator tracks 455 kc. above signal on both bands.

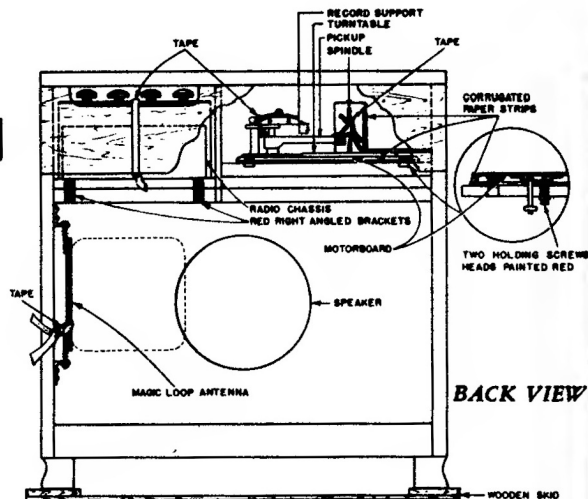

Critical Lead Dress:

1. Dress speaker cable leads down next to chassis.
2. Dress output plate capacitors next to chassis.
3. Dress plate lead of output tube away from grid of audio amplifier.
4. Dress all a-c leads away from volume control down next to chassis.
5. Dress R16 away from a-c leads at on-off switch.
6. Dress R2 away from side of chassis.

Note.—In order to remove the chassis from the cabinet, remove the knobs and the connecting cables, then unscrew the four slotted hex head screws from the two "L" brackets bolted to the rear of the chassis. The chassis may then be slid out toward the bottom rear of the cabinet. Do not remove the hinge screws or the two large nuts in the rear of the chassis. When replacing the chassis fit the holes on the metal runners screwed to the cabinet door.

