

SWITCH SHOWN IN EXTREME C/CLOCKWISE POSITION (PHONO) AS VIEWED FROM FRONT (KNOB END). TERM. 12 & 11 ARE NEAREST BASE

NOTE - VOLTAGES MEASURED WITH CHANALYST OR VOLTOHMYST & SHOULD HOLD WITHIN ± 20% WITH RATEU POWER SUPPLY.

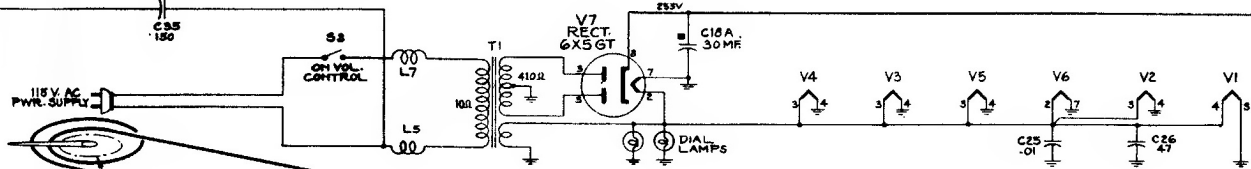

CRITICAL LEAD DRESS

1. Keep leads of C7 short.
2. Dress R27 away from range switch and pin No. 5 of V1.
3. The ground lead of pin No. 2 of V2 and V3 should be down against chassis. Its length is critical.
4. The AVC lead from R26 to range switch should be dressed against chassis and on front apron side of the output transformer.
5. C43 should have short leads and the color code of the capacitor should go to the coil L4. The capacitor should be cemented down with polystyrene cement at the same time L2 is cemented.
6. The lead from the high side of the loop should be dressed away from tubes.
7. Lead from pin No. 2 of V1 to terminal "A" of 1st I. F. transformer should be dressed against the chassis.
8. Connect C40 directly between the gang condenser and pin No. 1 of V1.
9. Make all FM leads as short as possible.
10. Dress lead from pin No. 5 of V2 to terminal "A" of 2nd I. F. transformer down against chassis.

11. Dress resistor R15 near chassis base.
12. Dress all A. C. leads away from volume control.
13. The lead from "FM" terminal of antenna terminal board to L1 tap should be run around the outside of the 1st I. F. transformer and away from V2.
14. The taps on L1 and L2 are critical. L1 tap should be 1/4 turn from the ground end. L2 tap should be 2 1/2 turns from the gang condenser C8.
15. The lead from R82 to terminal No. 9 of S1 should be dressed away from the output transformer.
16. Dress C25 and C26 against the chassis with the shortest lead length possible.
17. The position of L1 and L2 is critical. L1 should be midway between V1 and the 1st I. F. transformer. The end of L2 should be approximately 3/16" from V1.

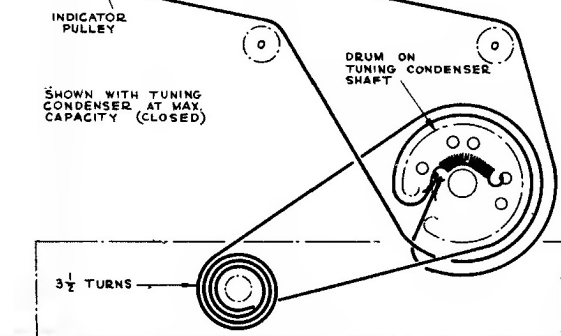

3 1/2 TURNS

RCA VICTOR

Alignment Procedure

8R71, 8R74, 8R75
Chassis No. RC-1060

8R72, 8R76
Chassis No. RC-1060A

**CORRECT ALIGNMENT OF THE FM BAND
REQUIRES THAT THE AM BAND BE
ALIGNED FIRST**

Alignment Indicators:

An RCA VoltOhmyst or equivalent meter is necessary for measuring developed d-c voltage during FM alignment. Connections are specified in the alignment tabulation. An output meter is also necessary to indicate minimum audio output during FM Ratio Detector alignment. Connect the output meter across the speaker voice coil.

The RCA VoltOhmyst can also be used as an AM alignment indicator, either to measure audio output or to measure a-v-c voltage.

When audio output is being measured the volume control should be turned to maximum.

Signal Generator:

For all alignment operations connect the low side of the signal generator to the receiver chassis. The output should be adjusted to provide accurate resonance indication at all times. If output measurement is used for AM alignment the output of the signal generator should be kept as low as possible to avoid a-v-c action.

The FM i-f alignment may be checked by means of an FM sweep generator and cathode ray oscilloscope. Connect the output from the sweep generator, which is set to 10.7 mc., to the mixer grid (6J6 Pin No. 5), low side to chassis. Disconnect the 2 mfd. capacitor C33 from the Ratio Detector circuit.

Connect the high side of the oscilloscope to the junction of R25 and R26, low side to chassis. Adjust the sweep generator and oscilloscope to obtain the response curve.

The Ratio Detector characteristic may be viewed by connecting the oscilloscope across the volume control R14. Capacitor C33 should be re-connected before checking the Ratio Detector characteristic.

AM Alignment

RANGE SWITCH IN BC POSITION

| Steps | Connect high side of sig. gen. to— | Sig. gen. output | Turn radio dial to— | Adjust for peak output |
|-------|---|------------------|-------------------------------|--|
| 1 | C3 in series with .01 mfd. | 455 kc. | Quiet point at low freq. end. | AM windings.† T3 bottom core (sec.). T3 top core (pri.). |
| 2 | | | | AM windings.† T2 top core (sec.). T2 bottom core (pri.). |
| 3 | "A" terminal of terminal board at rear of chassis in series with 220 mmf. | 1400. kc. | 1400 kc. | C13 osc. C4 ant. |
| 4 | | 600 kc. | 600 kc. | L4 osc. (Rock gang.) |
| 5 | Repeat Steps 3 and 4. | | | |

† Use alternate loading.

Alternate loading involves the use of a 47,000 ohm resistor to load the AM plate winding while the AM grid winding of the SAME TRANSFORMER is being peaked. Then the grid winding is loaded with the resistor while the plate winding is peaked. Only one winding is loaded at any one time. Remove the 47,000 ohm resistor after T3 and T2 have been aligned.

Oscillator frequency is above signal frequency on both AM and FM.

FM Alignment

RANGE SWITCH IN FM POSITION — VOLUME CONTROL MAXIMUM

| Steps | Connect high side of sig. gen. to— | Sig. gen. output | Turn radio dial to— | Adjust for peak output |
|-------|---|--|---------------------|--|
| 1 | Connect the d-c probe of a VoltOhmyst to the negative lead of the 2 mfd. capacitor C33 and the common lead to chassis. Turn gang condenser to max. capacity (fully meshed). | | | |
| 2 | Pin 1 of 6AU6 in series with .01 mfd. | 10.7 mc. modulated 30% 400 cycles AM (Approx. .05 volt). | | T4 top core for max. d-c voltage across C33. T4 bottom core for min. audio output.* |
| 3 | | 10.7 mc. Adjust to provide 2 to 3 volts indication on VoltOhmyst during alignment. | | Max. capacity (fully meshed). FM windings.†† T3 top core (sec.). T3 bottom core (pri.). |
| 4 | FM ant. term. in series with a 300 ohm resistor. (Remove ant. lead from "FM" term.) | | | FM windings.†† T2 top core (sec.). T2 bottom core (pri.). |
| 5 | | 106 mc. | 106 mc. | L2 osc.** T2 top core (sec.). Set C2 at max. capacity while adjusting L2. |
| 6 | | 90 mc. | 90 mc. | L1 ant.** (Rock gang.) |
| 7 | Repeat Steps 5 and 6 until further adjustment does not improve calibration. | | | |

* Two or more points may be found which lower the audio output. At the correct point the minimum audio output is approached rapidly and is much lower than at any incorrect point.

†† Align T3 and T2 by means of alternate loading as explained under AM alignment. Use a 680 ohm resistor instead of a 47,000 ohm resistor and load the FM windings.

** L1 and L2 are adjustable by increasing or decreasing the spacing between turns.

