

Sentinel Radio -- Model 323K

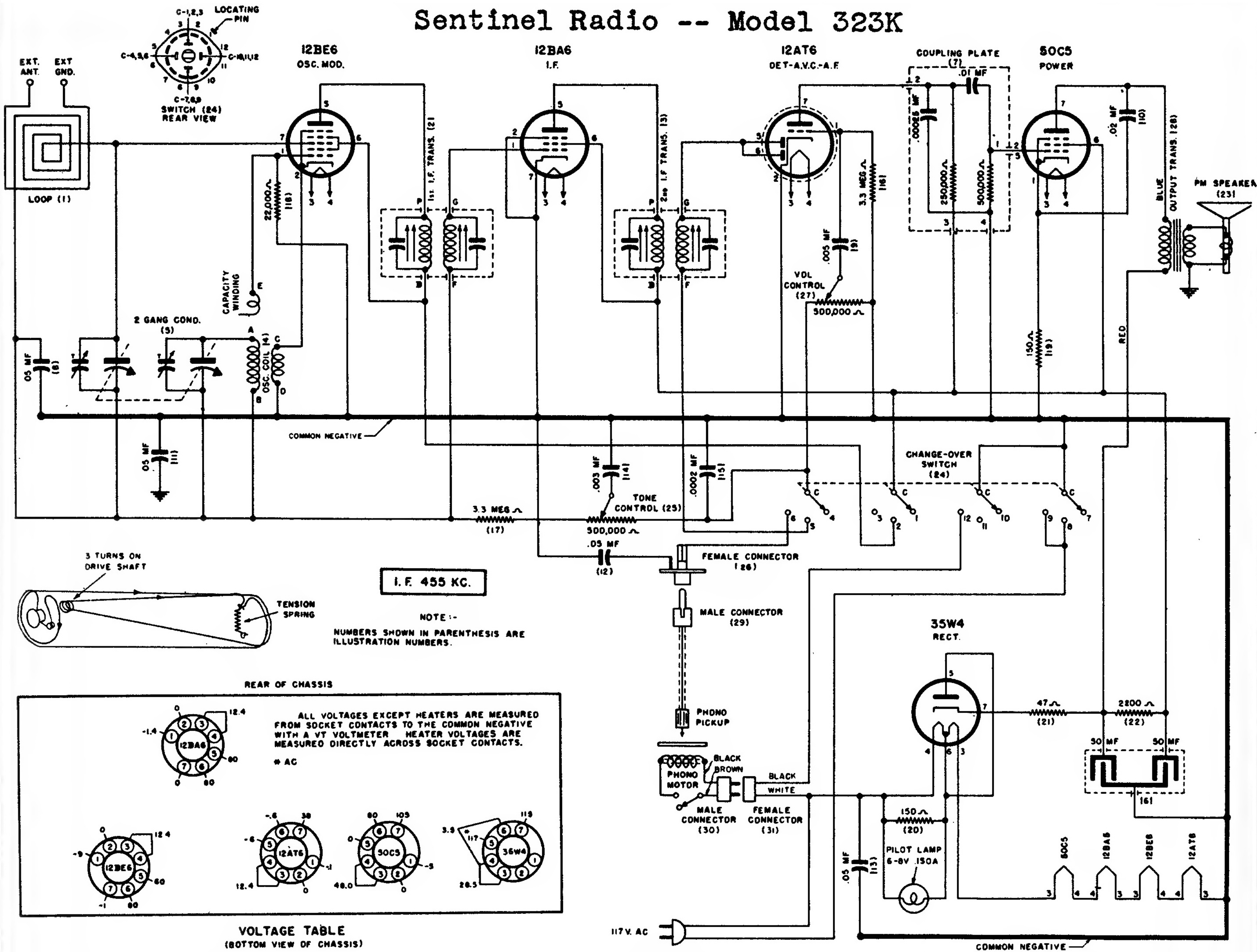

ALIGNMENT (C) Couple test oscillator to receiver loop by: (1) make loop consisting of 5 to 10 turns of No. 20 to No. 30 size wire, wound on a 2" or 3" form; (2) connect this loop across output of test oscillator; (3) place test oscillator loop near radio loop. BE SURE THAT NEITHER LOOP MOVES WHILE ALIGNING.

Steps	Set receiver dial to:	TEST OSCILLATOR			Refer to parts layout diagram for location of trimmers mentioned below:
		Adjust test oscillator frequency to:	Use dummy antenna in series with output of test oscillator consisting of:	Attach output of test oscillator to:	
1	Any point where no interfering signal is received	455 K. C.	.02 MFD. See Paragraph (C) Above	High side to rear stator plates of tuning condenser. Low side to frame of condenser through a .02 Mfd. blocking condenser.	Adjust each of the second I. F. transformer trimmers for maximum output—then adjust each of the first I. F. trimmers for maximum output.
2	Exactly 1650 K. C.	Exactly 1650 K. C.	See Paragraph (C) Above	See Paragraph (C) Above	Adjust 1650 K. C. oscillator trimmer for maximum output.
3	Approx. 1400 K. C.	Approx. 1400 K. C.	See Paragraph (C) Above	See Paragraph (C) Above	Adjust 1400 K. C. antenna trimmer for maximum output.

