

SPARTON SUPERHETERODYNE MODELS 5321 & 5521

BOTTOM VIEW OF ALL SOCKET CONNECTIONS.

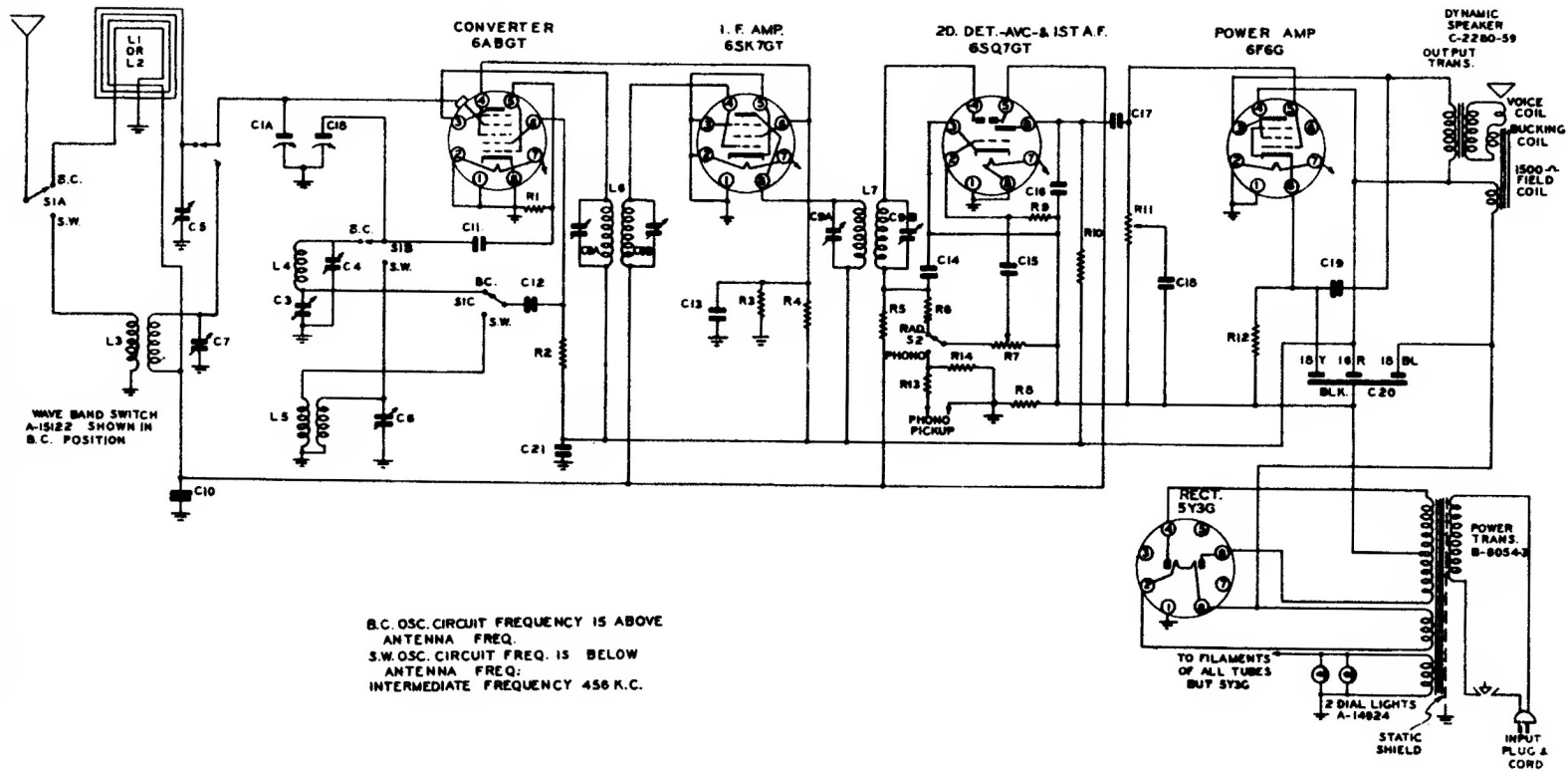

B.C. OSC. CIRCUIT FREQUENCY IS ABOVE
ANTENNA FREQ.
S.W. OSC. CIRCUIT FREQ. IS BELOW
ANTENNA FREQ.
INTERMEDIATE FREQUENCY 456 K.C.

C1A & B	VARIABLE CONDENSER	B-8235
C-3	B.C. OSC. PADDER	A-1575B-1
C-4	B.C. OSC. TRIMMER	
C-5	B.C. ANT. TRIMMER	A-1408B-5
C-6	S.W. OSC. TRIMMER	
C-7	S.W. ANT. TRIMMER	B-7200-GN
C8A & B	NO. 1 I.F. TRIMMER	B-7200-NH
C8A & B	NO. 2 I.F. TRIMMER	C-3206-28C
C10	.05 MFD. 600V.	C-720-372
C11	50 MMFD. MOLDED	C-3206-58C
C12	.001 MFD. 600V.	

C13	.1 MFD. 400V.	C-3204-38C
C14	250 MMFD. MOLDED	R-720-319
C15	.02 MFD. 400V.	C-3204-22C
C16	100 MMFD. MOLDED	C-720-339
C17	.02 MFD. 600V.	C-3208-22C
C18	.008 MFD. 400V.	C-3204-68C
C19	.008 MFD. 600V.	C-3206-68C
C20	18-18-10 MFD. ELECT.	A-14780-1
C21	.1 MFD. 600V.	C-3208-38C

R1	33000 Ω .25W.	C-2795-80B
R2	22000 Ω .5W.	C-2798-78C
R3	47000 Ω 1W.	C-2797-82B
R4	22000 Ω 2W.	C-2798-81A
R5	3.3 MEG. .25W.	C-2795-104B
R6	27000 Ω .25W.	C-2795-79B
R7	5 MEG. Ω VOL. CONT.	A-15130-5
R8	56 Ω .5W.	C-2798-47C
R9	5.6 MEG. .25W.	C-2795-107B
R10	270,000 Ω .25W.	C-2795-91B
R11	5 MEG. TONE CONT. & S.W. A-15129-2	
R12	660 Ω 1W.	C-2797-80B
R13	270,000 Ω .25W.] 5521	C-2795-91B
R14	270,000 Ω .25W.] ONLY	C-2795-91B

L1	B.C. ANT. COIL-5521-	C-3290-8
L2	B.C. ANT. COIL-5321-	C-3290-9
L3	S.W. ANT. COIL	A-14862-15
L4	B.C. OSC. COIL	A-15920-1
L5	S.W. OSC. COIL	A-15233-18
L6	NO. 1 I.F. COIL	A-12064-39
L7	NO. 2 I.F. COIL	A-12064-49

S1A-B	C	WAVE BAND SW.	A-15122
S2		PHONO-RADIO SW.	A-15754-1