

REFERENCE DOT
ANTENNA COIL
502277

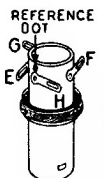

REFERENCE DOT
OSCILLATOR COIL
502278

Lettered terminals in illustrations correspond to similarly lettered terminals on the circuit diagram.

**I. F.
455 KC.**

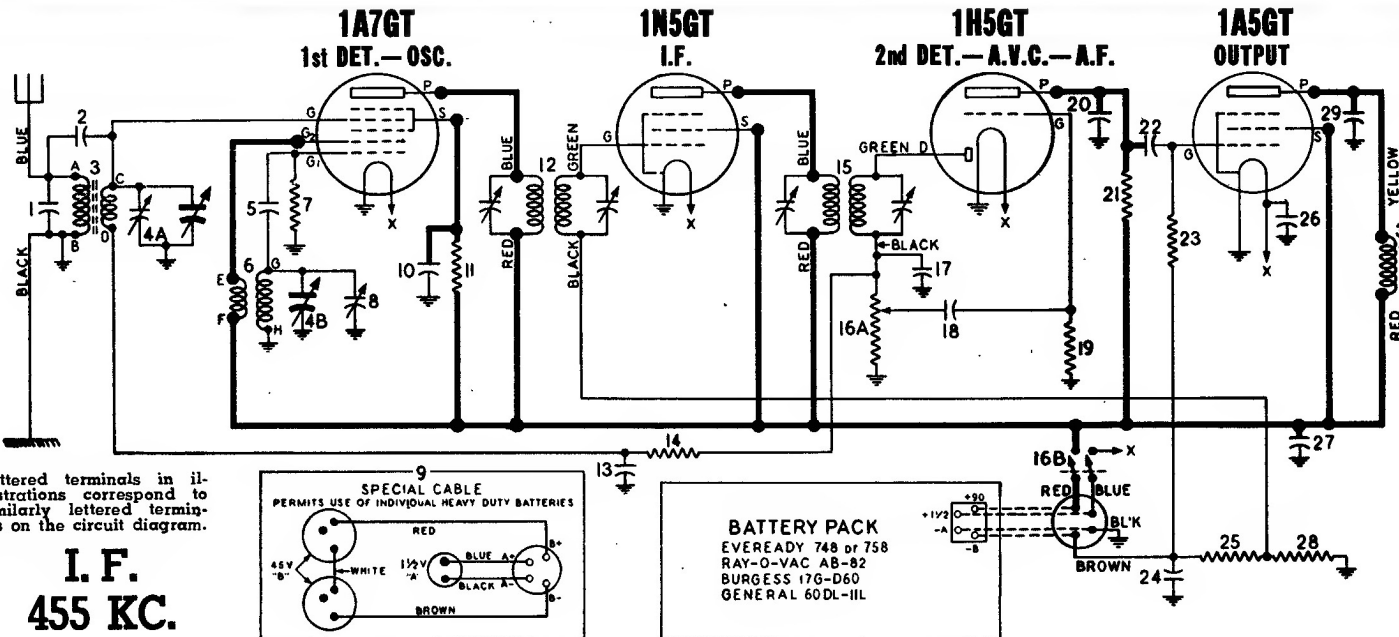

SOCKET VOLTAGES

Measured with voltmeter having sensitivity of 1000 ohms per volt except where indicated (*).

VOLUME ON FULL WITH NO SIGNAL DIAL TUNED TO 540 KC.

DIA-GRAM NO.	PART NO.	DESCRIPTION
CONDENSERS		
1	502159	Condenser—mica—50 Mmfd. 500 volt.....
2	502411	Condenser—2 Mmfd. 500 volt.....
4A, B	119528	Condenser—variable gang.....
5	502159	Condenser—mica—50 Mmfd. 500 volt.....
8	119719	Condenser—trimmer 5 to 50 Mmfd.....
10	502157	Condenser—.05 Mfd. 400 volt.....
13	502157	Condenser—.05 Mfd. 400 volt.....
17	502160	Condenser—mica—110 Mmfd. 500 volt.....
18	502151	Condenser—.01 Mfd. 400 volt.....
20	502271	Condenser—mica—260 Mmfd. 500 volt.....
22	502151	Condenser—.01 Mfd. 400 volt.....
24	502286	Condenser—electrolytic 10 Mfd. 25 volt.....
26	502263	Condenser—.5 Mfd. 150 volt.....
27	502262	Condenser—.25 Mfd. 200 volt.....
29	502260	Condenser—.002 Mfd. 600 volt.....
RESISTORS		
7	502133	Resistor—carbon—220,000 ohms 1/4 watt.....
11	502266	Resistor—carbon—15,000 ohms 1/4 watt.....
14	502269	Resistor—carbon—3.3 Meg. 1/4 watt.....
16A, B	161325	Volume control (with switch) 500,000 ohms.....
19	502269	Resistor—carbon—3.3 Meg. 1/4 watt.....
21	502267	Resistor—carbon—680,000 ohms 1/4 watt.....
23	502268	Resistor—carbon—1 Meg. 1/4 watt.....
25	502127	Resistor—carbon—560 ohms 1/4 watt.....
28	502264	Resistor—carbon—47 ohms 1/4 watt.....

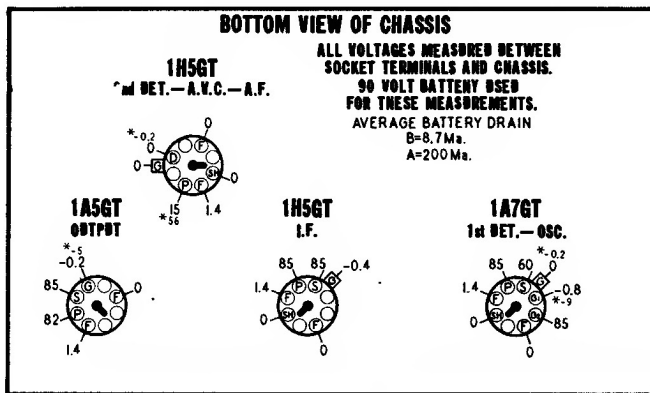

REAR OF CHASSIS

*—Measured with vacuum tube voltmeter

STEWART-WARNER MODELS 9005-A, B.

STEWART-WARNER MODELS 9005-A, B.

When gang condenser is fully meshed, dial pointer should be in the position indicated by the 54 mark on the dial. If it is set incorrectly, release the pointer clip on the dial cord and reposition pointer.

Connect an output meter across speaker voice coil or from the plate of the 1A5GT tube to chassis through a 0.1 Mfd. condenser.

Connect the ground lead of the signal generator to the receiver ground lead (black) or to the chassis.

Set volume control to maximum volume position and use a weak signal from the signal generator.

DUMMY ANT. IN SERIES WITH SIGNAL GENERATOR	CONNECT HIGH SIDE OF SIG. GENERATOR TO	SIGNAL GENERATOR FREQUENCY	RECEIVER DIAL SETTING	TRIMMER NUMBER	TRIMMER DESCRIPTION	TYPE OF ADJUSTMENT
.1 MFD. Condenser	Grid cap on 1A7GT tube	455 KC	Any point where it does not affect the signal	1-2	2nd I.F.	Adjust for maximum output. Then repeat adjustment.
				3-4	1st I.F.	
200 MMFD. Mica Condenser	External antenna lead (blue)	1500 KC	1500 KC	5	Broadcast Oscillator	Adjust for maximum output.
200 MMFD. Mica Condenser	External antenna lead (blue)	1500 KC	Tune to 1500 KC generator signal	6	Broadcast Antenna	Adjust for maximum output.

APPROXIMATE STAGE GAIN DATA

Be sure R.F. and I.F. stages are accurately aligned before measuring gain. R.F. gains can be measured with a "channel" type instrument containing a tuned and calibrated R.F. amplifier. A vacuum tube voltmeter may be used for audio gain measurements. Observe following precautions.

- For all gain measurements connect signal generator as shown. Use 600 KC signal with 400 cycles modulation (use nearby frequency if local station interferes.)
- For R.F. and I.F. measurements connect negative terminal of a 1½-volt battery to A.V.C. lead and positive terminal to chassis. This provides a definite operating point.
- Be sure radio is carefully tuned to generator signal (use weak signal for sharp tuning.)
- When using a "channel" type instrument carefully tune it for maximum output at desired frequency before making measurements.

The R.F. and I.F. stage gains shown below are less than under normal operating conditions due to the use of 1½ volts fixed bias in order to establish a definite operating point. Therefore, these values are not intended to indicate the full capability of a stage.

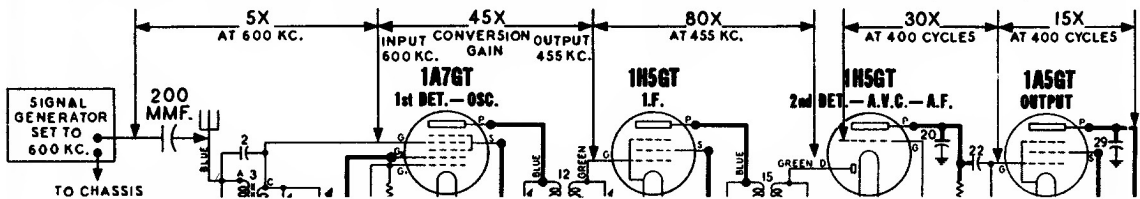

Differences in tube characteristics, tolerance of parts, adjustment of tuned circuits, and variations of line voltage will influence stage gain. Accuracy of measurements is dependent upon careful tuning of receiver to generator signal and experience in using your test equipment. These factors may create considerable variation in gain measurements.

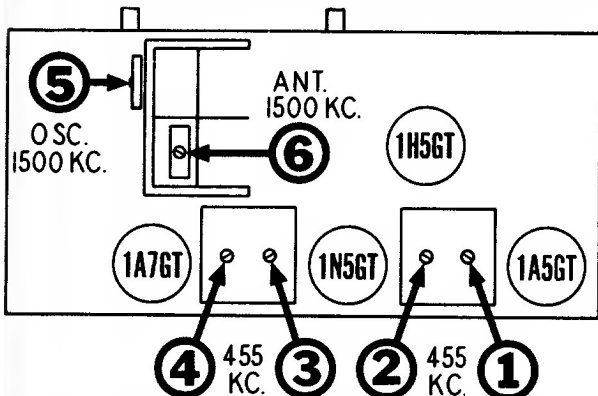

DIAL AND POINTER DRIVE CORD ARRANGEMENT

To string dial cord, set gang condenser to fully meshed position and use following parts:

- 114955 Clip on end of cord
- 117057 Cord (36 inches)
- 119087 Ring for dial cord
- 114968 Tension Spring

POWER LINE OPERATION

The following power pack may be used to operate this set on 110 volt 50-60 cycle A.C. power lines.

Porta-Power Model "H"
This unit is manufactured by the General Transformer Corp., 1250 W. Van Buren St., Chicago, Ill.

