

# STEWART-WARNER AM-FM RADIO MODEL 9151-A

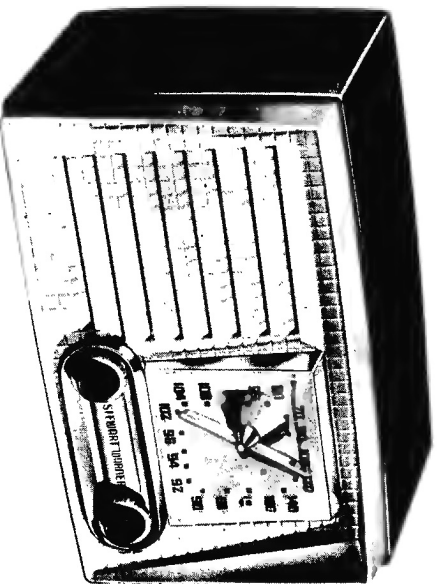

## HOW TO REMOVE CHASSIS FROM CABINET

1. Remove all knobs by pulling them forward.
2. Take off dial scale by pressing down on top center of plastic dial enclosure and at the same time pulling it forward.
3. Remove pointer by pulling it forward.
4. Remove cabinet back by taking out three screws and two clips.  
Note: Cabinet back has a power cord interlock which is automatically disconnected when back is removed.
5. Take out two chassis mounting screws at bottom of cabinet. Chassis may now be readily removed by sliding it out of cabinet.
6. When replacing cabinet back be sure that it is parallel to loop and power cord interlock plug fits into socket on chassis.

TERMINAL D IS LOCATED  
3/4 TURN FROM  
TERMINAL C

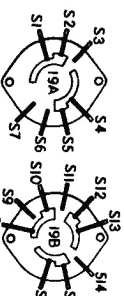

SECTION 1 FRONT VIEW  
SECTION 1 REAR VIEW  
BAND SWITCH 508231

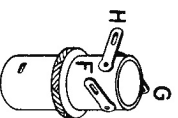

AM OSC.  
COIL  
507939



FM R.F.  
COIL  
508224

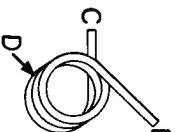

FM OSC.  
COIL  
508225

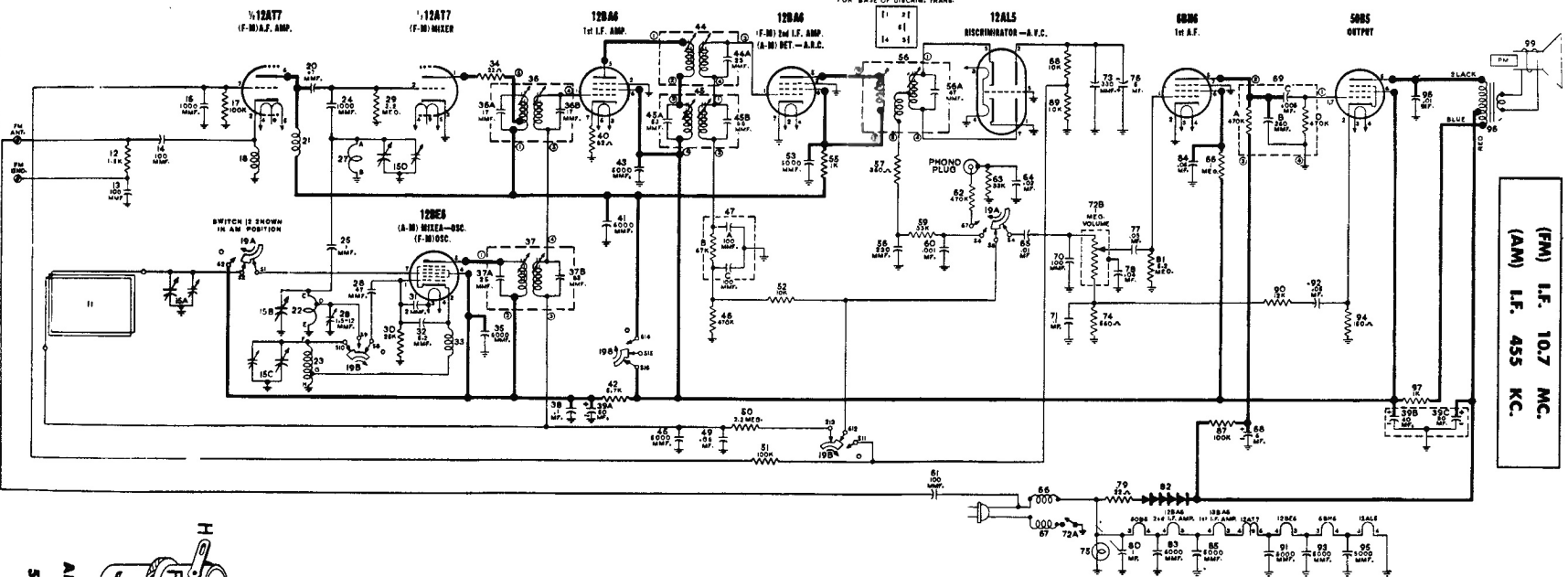

(FM) I.F. 10.7 MC.  
(AM) I.F. 455 KC.

Lettered terminals in illustrations correspond to similarly lettered terminals on the circuit diagram.



## Stewart-Warner Model 9151-A, Continued

### FREQUENCY MODULATION—"FM"—ALIGNMENT PROCEDURE

1. If alignment of both AM and FM channels are required it is advisable to align the AM channel first as instructed in chart on Page 158. Then, accomplish FM channel alignment by using the procedure outlined in the chart below.
2. Remove chassis and loop antenna (which is mounted to chassis) from cabinet by following procedure outlined on Page 157. Allow loop to remain attached to chassis.
3. Disconnect built-in FM lead from "FM ANT." terminal at back of chassis.
4. Set band switch to the "FM" (middle) position.
5. Set volume control at maximum and use a weak signal from the signal generator.
6. Dress FM circuit leads as short and straight as possible, particularly those in the oscillator circuit. IF plate and grid leads should also be kept short and straight.
7. Since the dial scale is a part of the cabinet, when completely assembled, it becomes necessary to provide a temporary means of locating the dial to obtain calibration points. Rotate gang condenser fully counter-clockwise and replace pointer so that it is parallel with base of the chassis. Now, hold dial scale in front of pointer in such a position that the ends of the indicator point to the "AM" and "FM" markers. While holding the dial scale in this position, rotate tuning sleeve until painter indicates desired frequency.

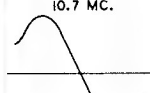
STANDARD SIGNAL GENERATOR		SWEEP GENERATOR		VTVM OR OUTPUT METER CONNECTION	OSCILLOSCOPE CONNECTIONS	RECEIVER DIAL SETTING	TRIMMER OR SLUG NUMBER	TYPE OF ADJUSTMENT AND OUTPUT INDICATION
CONNECTIONS	FREQUENCY	CONNECTIONS	FREQ.					
Connect high side to lug on trimmer #13 (see Fig. 1 for location of trimmer) using a .01 Mfd. condenser in series with generator lead. Connect ground lead to the receiver chassis in vicinity of gang condenser.  <b>CAUTION:</b> If your signal generator is designed with an AC-DC type power supply, connect ground lead of signal generator to receiver chassis through a .25 Mfd. condenser.	<b>10.7 MC.</b> Unmodulated	Not used.	_____	Connect VTVM as shown in Fig. 3.	Not used.	Any position where it does not affect the signal.	#7 Discriminator secondary  #8 Discriminator primary  #9-10 2nd IF  #11-12 1st IF	Adjust these trimmers for maximum meter reading — the output voltage will be of negative polarity.  Note that as slug #7 is rotated, a point will be found where the voltmeter will swing rather sharply from a positive to a negative reading or vice versa. The correct setting is obtained when the meter reads zero as the slug is moved thru this point.
Same as above.	Same as above.	Not used.	_____	Connect VTVM as shown in Fig. 4.	Not used.	Same as above.	#7 Discriminator secondary	A pattern similar to that shown in Fig. 5 should appear on the oscilloscope screen. Check for symmetry about the 10.7 Mc. center point and linearity of the slope.  10.7 MC.  
Same as above.	Same as above.  Attenuate signal to prevent overload and distortion of response curve.	Connect high side to lug on trimmer #13 (see Fig. 1 for location of trimmer) using a .01 Mfd. condenser in series with generator lead. Connect ground lead to the receiver chassis in vicinity of gang condenser.  <b>CAUTION:</b> If your signal generator is designed with an AC-DC type power supply, connect ground lead of signal generator to receiver chassis through a .25 Mfd. condenser.	<b>10.7 MC</b> Sweeping ±300 Kc.	Not used.	Connect as shown in Fig. 4.  Set vertical amplifier of scope for maximum amplification.  Synchronize oscilloscope with sweep generator by connecting "horizontal input" terminals of scope to source of horizontal sweep modulating voltage on the sweep generator.	Same as above.	#7 Discriminator secondary	FIG. 5 If not shaped properly, attempt to obtain symmetry by changing the setting of slug #7. Should that fail to produce the desired results, then a slight readjustment of slugs #8, 9, 10, 11 and 12 should be undertaken.
Connect high side in series with a 270 ohm carbon resistor to "FM ANT." terminal at rear of chassis. Connect ground lead to "FM GND." terminal.	<b>108 MC.</b> with 400 cycle AM Modulation.	Not used.	_____	Connect VTVM as shown in Fig. 3.	Not used.	108 Mc. See Step 7 above for instructions on how to obtain this calibration point.	#12 FM Oscillator	Set trimmer #12 to receive 108 Mc. signal as indicated by maximum meter reading.
Same as above.	<b>108 MC.</b> with 400 cycle AM Modulation.	Not used.	_____	Same as above.	Not used.	Tune to 108 Mc. generator signal.	#13 FM RF	Adjust trimmer for maximum meter reading.

Check calibration and tracking of receiver with input signals of 88 and 98 MC. If difference between dial painter setting and the above mentioned frequencies does not exceed ±0.3 MC. and RF circuit is tracking properly then alignment may be considered satisfactory and no further adjustment is necessary. Where the calibration error is greater than ±0.3 MC. it is advisable to make the following adjustments:

Tune receiver to an 88 MC. signal and note whether dial pointer is above or below correct calibration point. Then tune receiver so that dial pointer is at the 88 MC. position. If generator signal was previously received at a setting above 88 MC., it will be necessary to slightly spread the windings of the FM oscillator coil (#14 in Fig. 2) so that signal will now be received at the correct

dial setting. On the other hand, if generator signal was received at a dial setting below 88 MC., then slightly compress the windings of the oscillator coil until the signal comes in at the correct calibration point.

Check calibration at 108 MC. and if it is in error by more than ±0.3 MC., readjust setting of trimmer #12. Repeat calibration adjustment at 88 and 108 MC. until desired accuracy is obtained.

Observe dial calibration at 98 MC. If it is found to be incorrect by an appreciable amount, then make a very slight adjustment in the spacing of the gang condenser plates to receive the 98 MC. signal at the correct dial setting. Then check adjustment of RF trimmer #13 to obtain maximum output.