

Teletone

**5 TUBE, A.C.-D.C. SUPER HETERODYNE RADIO RECEIVER  
TELEPHONE MODEL NO. 230 — BO CHASSIS**

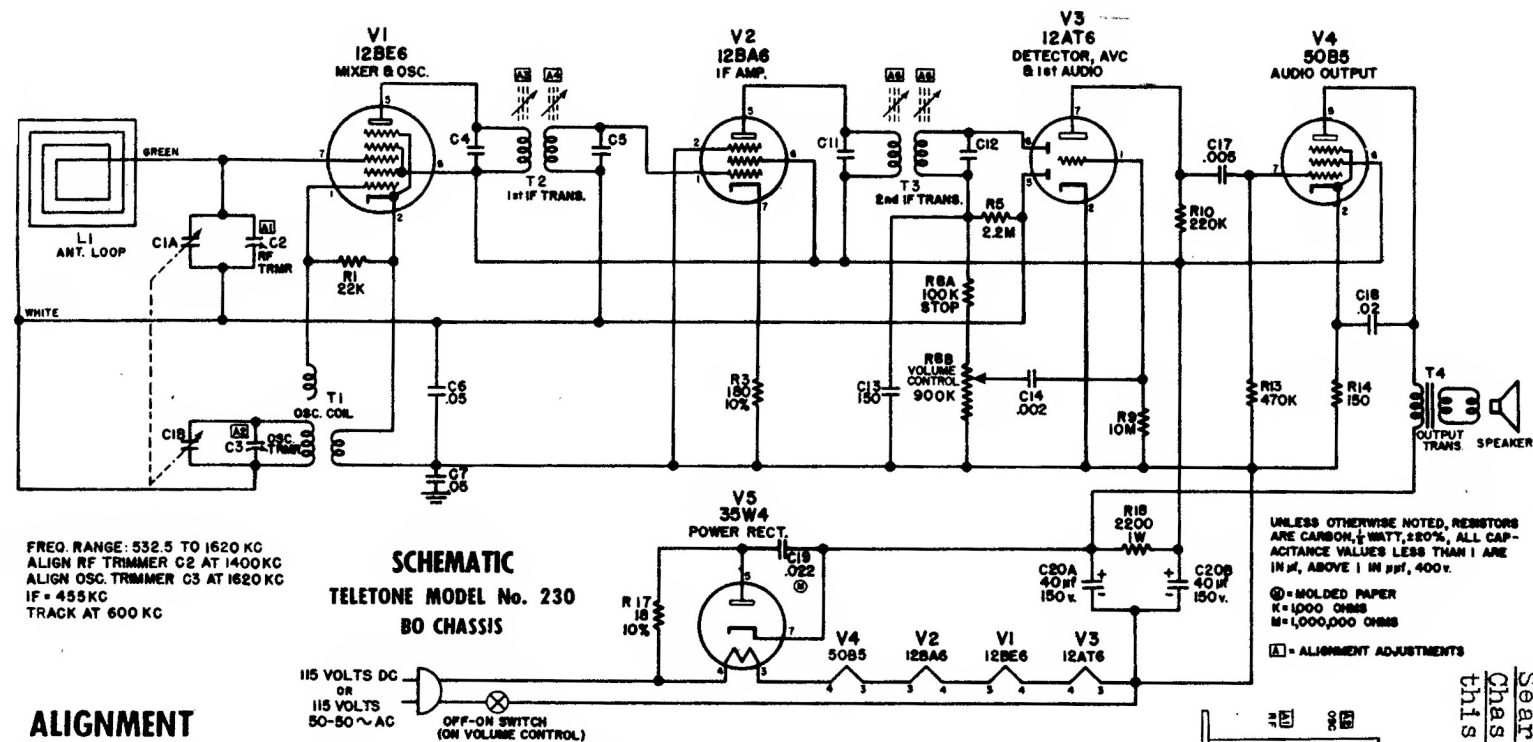

**SCHEMATIC**  
TELEPHONE MODEL No. 230  
BO CHASSIS

FREQ. RANGE: 532.5 TO 1620 KC  
ALIGN RF TRIMMER C2 AT 1400KC  
ALIGN OSC. TRIMMER C3 AT 1620 KC  
IF = 455 KC  
TRACK AT 600 KC

UNLESS OTHERWISE NOTED, RESISTORS ARE CARBON, 1/4 WATT, ±20%, ALL CAPACITANCE VALUES LESS THAN 1 ARE IN μF, ABOVE 1 IN pF, 400V.  
Ⓞ = MOLDED PAPER  
K = 1,000 OHMS  
M = 1,000,000 OHMS  
ⓐ = ALIGNMENT ADJUSTMENTS

**ALIGNMENT**

Position of Variable	SIGNAL GENERATOR				Trimmer Adjustments (in order shown) for maximum output
	Frequency	Dummy Antenna	Connection to Receiver	Ground Connection	
<b>IF</b> Rotor full open (plates out of mesh)	455 Kc	.05 Mfd.	Grid of 12BE6 (pin 7)	Chassis	Input & output trimmers on IF cans <b>A3</b> <b>A4</b> <b>A5</b> <b>A6</b>
<b>RF</b> Rotor full open (plates out of mesh)	1620 Kc		*Test Loop	*Test Loop	Oscillator Trimmer <b>A2</b>
	1400 Kc		*Test Loop	*Test Loop	Antenna Trimmer <b>A1</b>
	600 Kc		*Test Loop	*Test Loop	(Check Point)**

\*Connect generator lead to Hazeltine Test Loop, Model 1150, placed two feet from the set loop, or three turns of wire about six inches in diameter, placed about one foot from the set loop.

\*\*With a generator signal of 600 Kc, turn the set to the point where maximum output is obtained, which

should be approximately 600 Kc on the dial. Adjust antenna section plates of variable for maximum output.

The alignment procedure should be done in the order given for greatest accuracy. Align for maximum output. Reduce input to keep output near 0.4 volts.

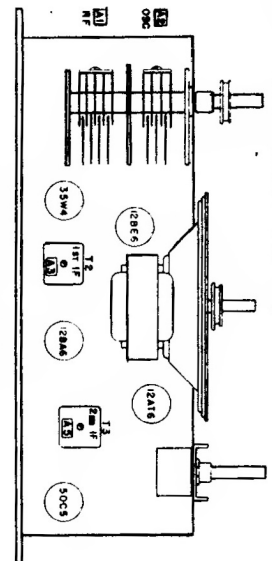

**TOP VIEW OF CHASSIS**

Sears, Roebuck Sets Nos. 13 & 14, Chassis 478.259, are similar to this Tele-Tone model.