

WESTERN AUTO SUPPLY COMPANY

MODEL D-2263

FACTORY MODEL 234031

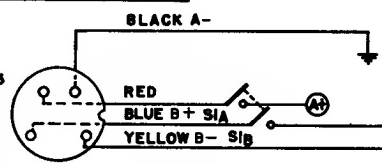
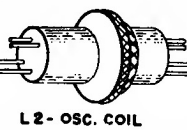
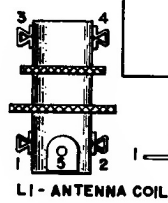
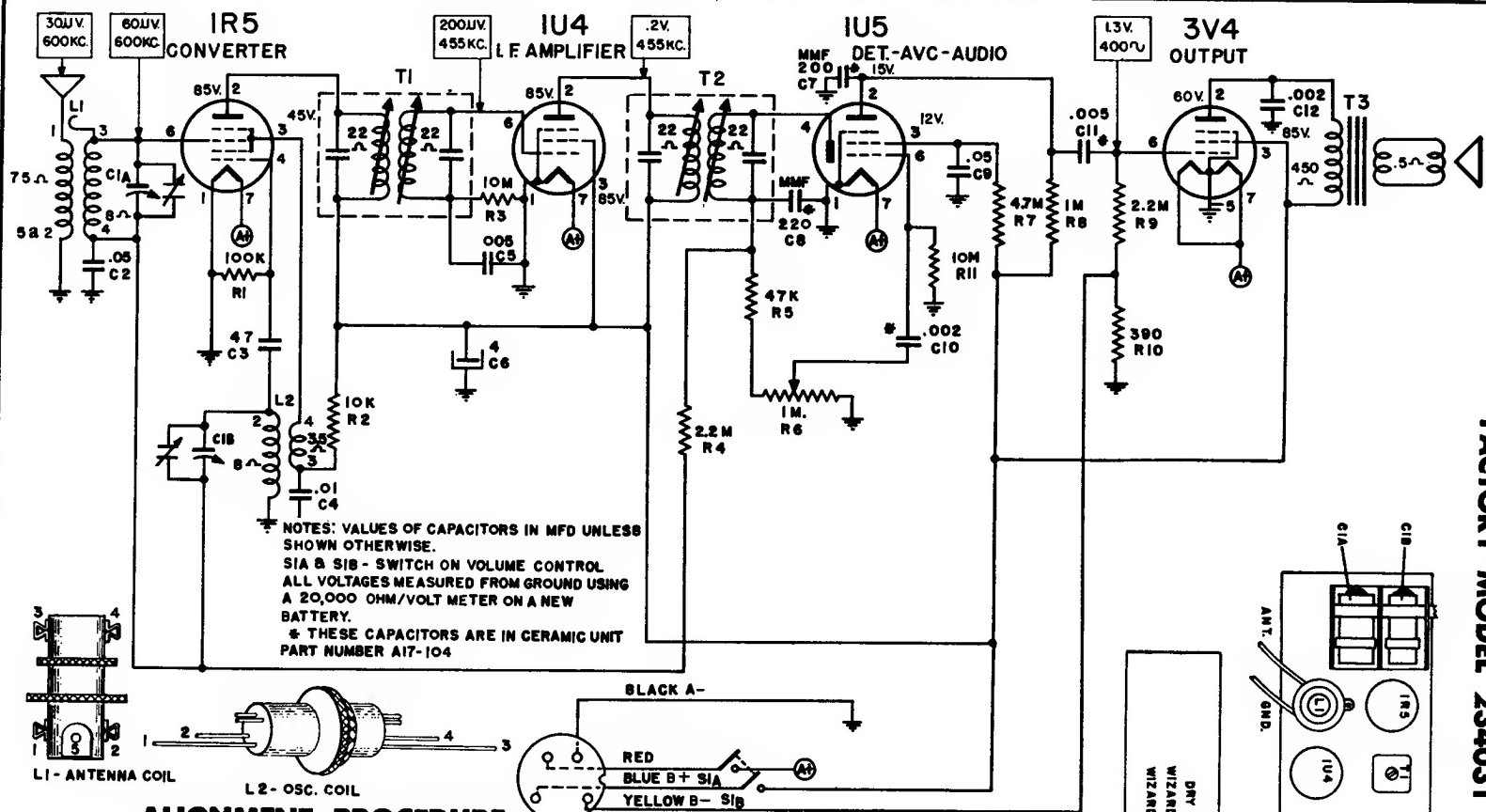

ALIGNMENT PROCEDURE

Position of Tuner	Generator Freq.	Dummy Antenna	Generator Connection	Adjustments (in order shown)	Function	Max. Microvolts Input to produce .05 w. output
Min. Cap.	455 kc	0.1 mfd.	Pin #6 of 1U4 I-F Amp.	T2 (top and bottom)	I.F.	5000
Min. Cap.	455 kc	0.1 mfd.	Pin #6 of 1R5 Conv.	T1 (top and bottom)	I.F.	100
Min. Cap.	1625 kc	0.1 mfd.	Stator ant. tuner	C2	Osc.	
1400 kc	1400 kc	200 mmfd.	Antenna lead	C1	Antenna coil	35

