

WESTERN AUTO SUPPLY COMPANY

MODEL D-3210A

Factory Model 4P12-A

NOTE: R-13 is now 2650 ohms.  
R-16 removed to increase sensitivity.

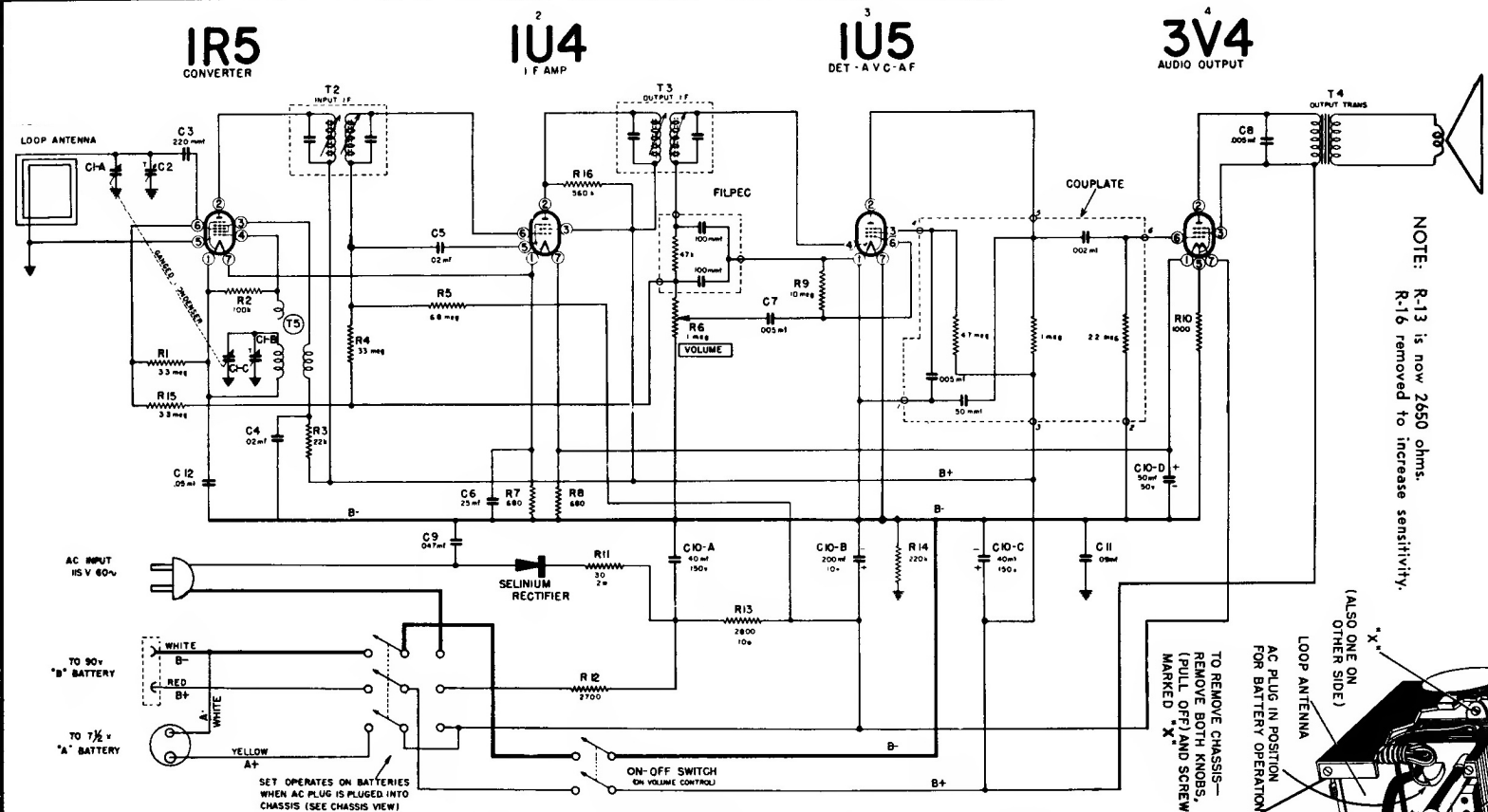

TO REMOVE CHASSIS—  
REMOVE BOTH KNOBS,  
(PULL OFF) AND SCREWS,  
MARKED "X".

AC PLUG IN POSITION  
FOR BATTERY OPERATION

LOOP ANTENNA  
(ALSO ONE ON  
OTHER SIDE)

"A" BATTERY

"B" BATTERY

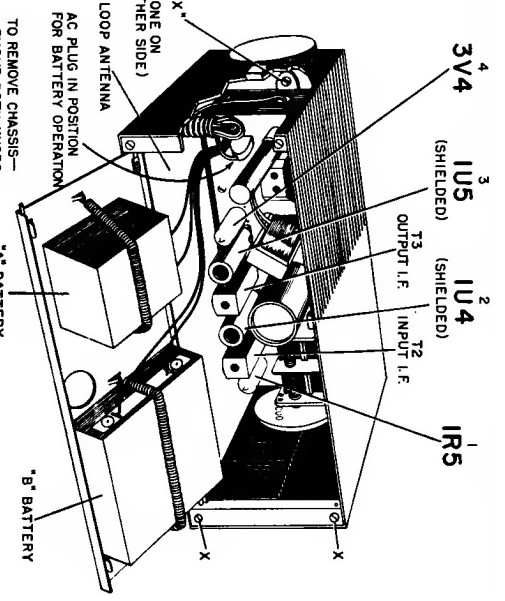

FREQUENCY	COUPLING CAPACITOR	DIAL SETTING	CONNECTION TO RADIO	GROUND CONNECTION	ADJUST	INPUT FOR 50 MILLIWATTS OUTPUT
455 kc.	.1 mfd.	1000 kc.	Pin No. 6 of 1R5	B— (shell of lytic)	I.F. slugs	100 microvolts
1620 kc.	.1 mfd.	1600 kc.	Pin No. 6 of 1R5	B— (shell of lytic)	C1-B Osc. Trim. on gang	—
1400 kc.	Radiation Loop	1400 kc.	Radiation loop	None	C-2 Antenna Trim. on gang	250 microvolts
400 cycles	.05 mfd.	—	Pin No. 6 of 1U5	B— (shell of lytic)	—	.040 volts
400 cycles	.05 mfd.	—	Pin No. 6 of 3V4	B— (shell of lytic)	—	3 volts

SET OPERATES ON BATTERIES  
WHEN AC PLUG IS PLUGGED INTO  
CHASSIS (SEE CHASSIS VIEW)