

Westinghouse Electric H-300T5 AND H-301T5

CHASSIS NO. V-2148

ALIGNMENT

It is recommended that the chassis be isolated from the power line by means of an isolation transformer.

Make certain that the dial pointer is correctly positioned with respect to the dial scale.

While making the following adjustments, keep the volume control set for maximum output and the signal generator output attenuated to avoid AVC action.

Step	Connect Signal Generator to —	Signal Generator Frequency	Radio Dial	Adjust for Maximum Output —
1.	Stator of R-F tuning capacitor (C13) through a 200 mmf capacitor	455 kc.	minimum capacity	Top and bottom slugs in 2nd and 1st I-F trans. in order given *
2.	Same as step 1	1615 kc.	minimum capacity	Osc. trimmer (C16)
3.	Radiated Signal	1400 kc.	1400 kc.	R-F trimmer (C15)

* It is recommended that a fiber aligning tool that snugly fits the slot in the powdered iron core be used to prevent chipping of the slot.

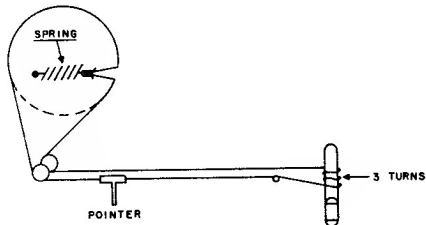

DIAL DRIVE

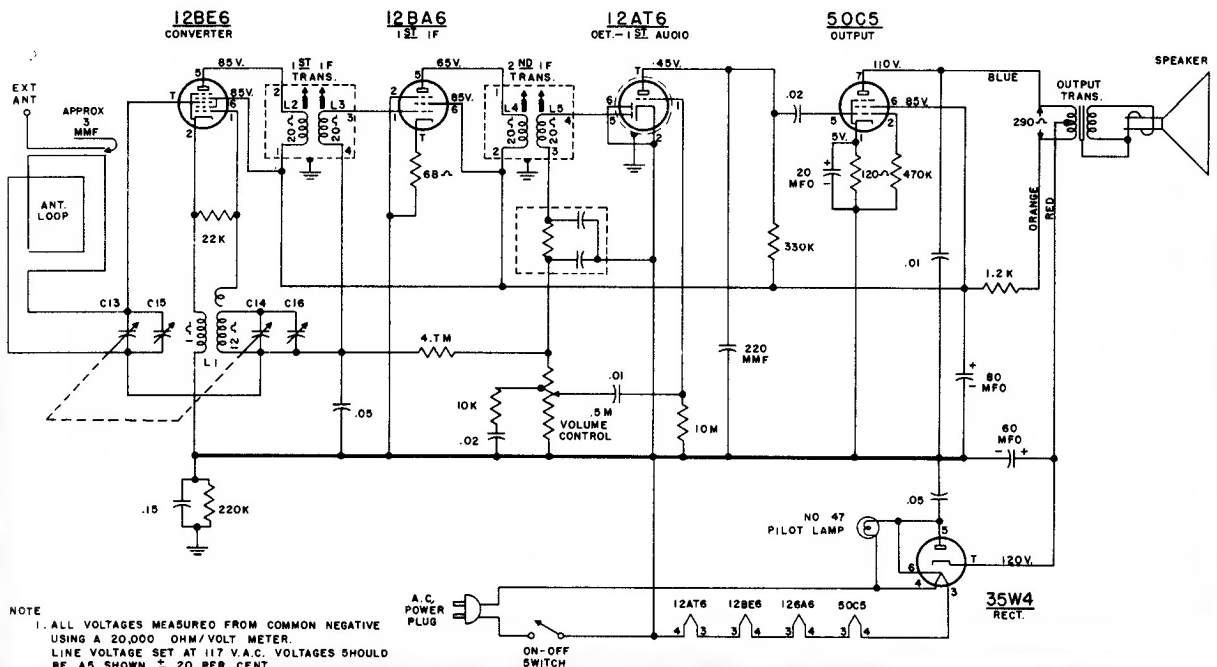
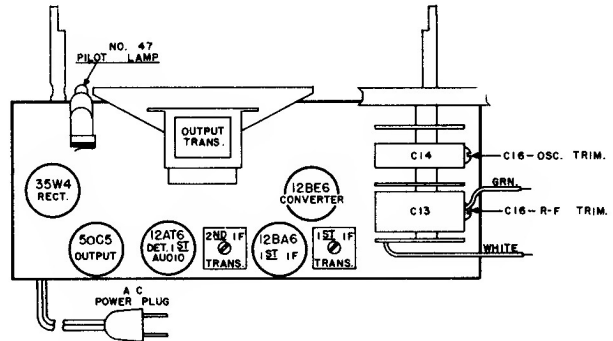

NOTE
1. ALL VOLTAGES MEASURED FROM COMMON NEGATIVE USING A 20,000 OHM/VOLT METER.
LINE VOLTAGE SET AT 117 V.A.C. VOLTAGES SHOULD BE AS SHOWN \pm 20 PER CENT.