

WR-258 WR-260

Westinghouse
Radio

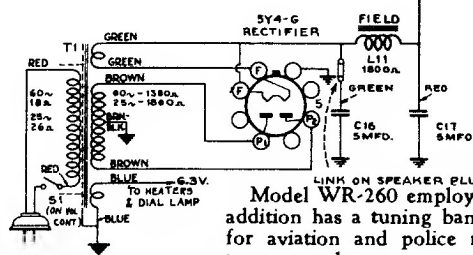

Model WR-260 employs all features of the WR-258 and in addition has a tuning band covering from 1,550 to 3,500 kc for aviation and police reception. It also has a two-point tone control.

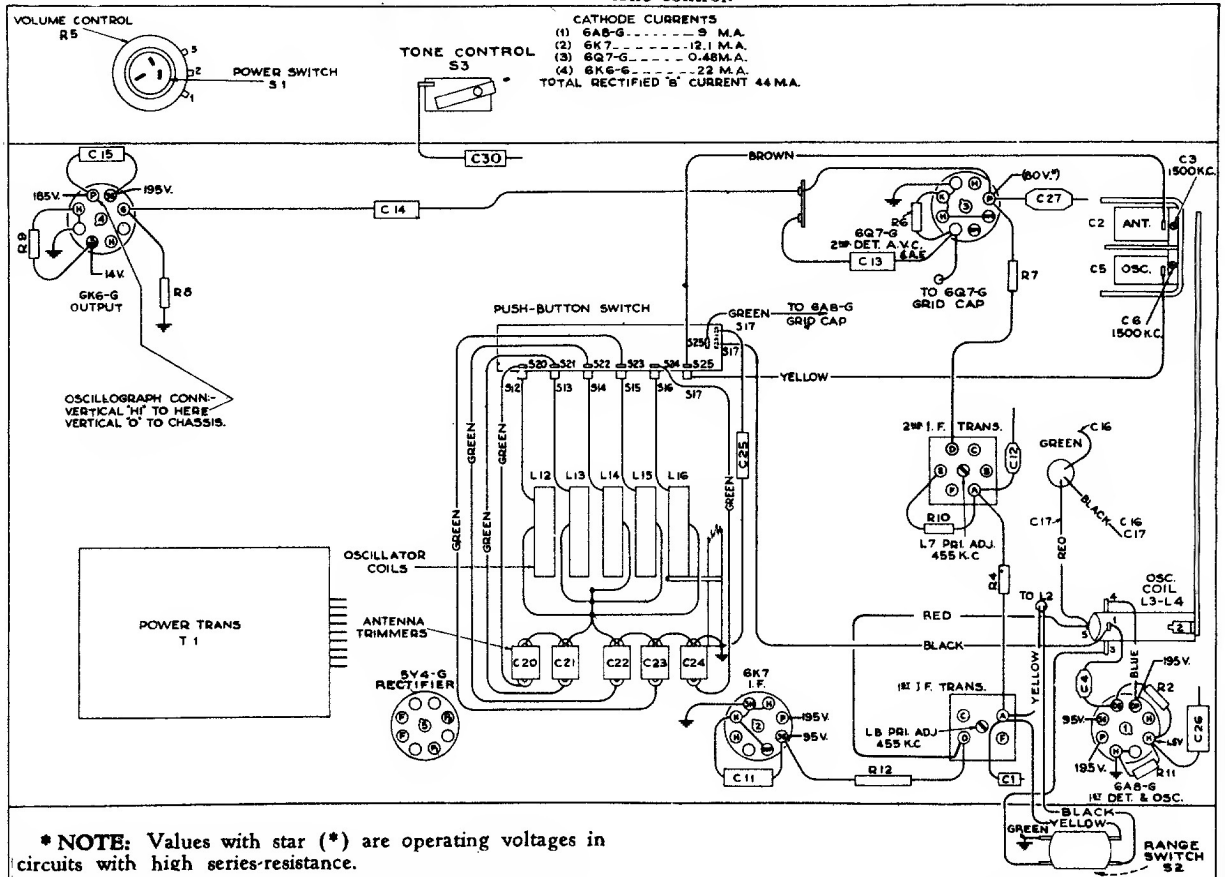

* NOTE: Values with star (*) are operating voltages in circuits with high series-resistance.

WR-260 Bottom View of Chassis Showing Socket Voltages, Parts Location, and R-F Wiring

Measurements made to chassis unless otherwise indicated, with set tuned to quiet point and volume control at minimum. Values should hold within approximately $\pm 20\%$ with 117-volt a-c supply.