

BOTTOM VIEW OF TUBE SOCKETS

IR5
CONVERTER

IN5GT
IF

IH5GT
DET.-AMP.

IC5GT[®]
PWR. AMP.

ALL VOLTAGES MEASURED FROM COMMON RETURN TO POINTS INDICATED WITH A D.C. VACUUM TUBE VOLT-METER

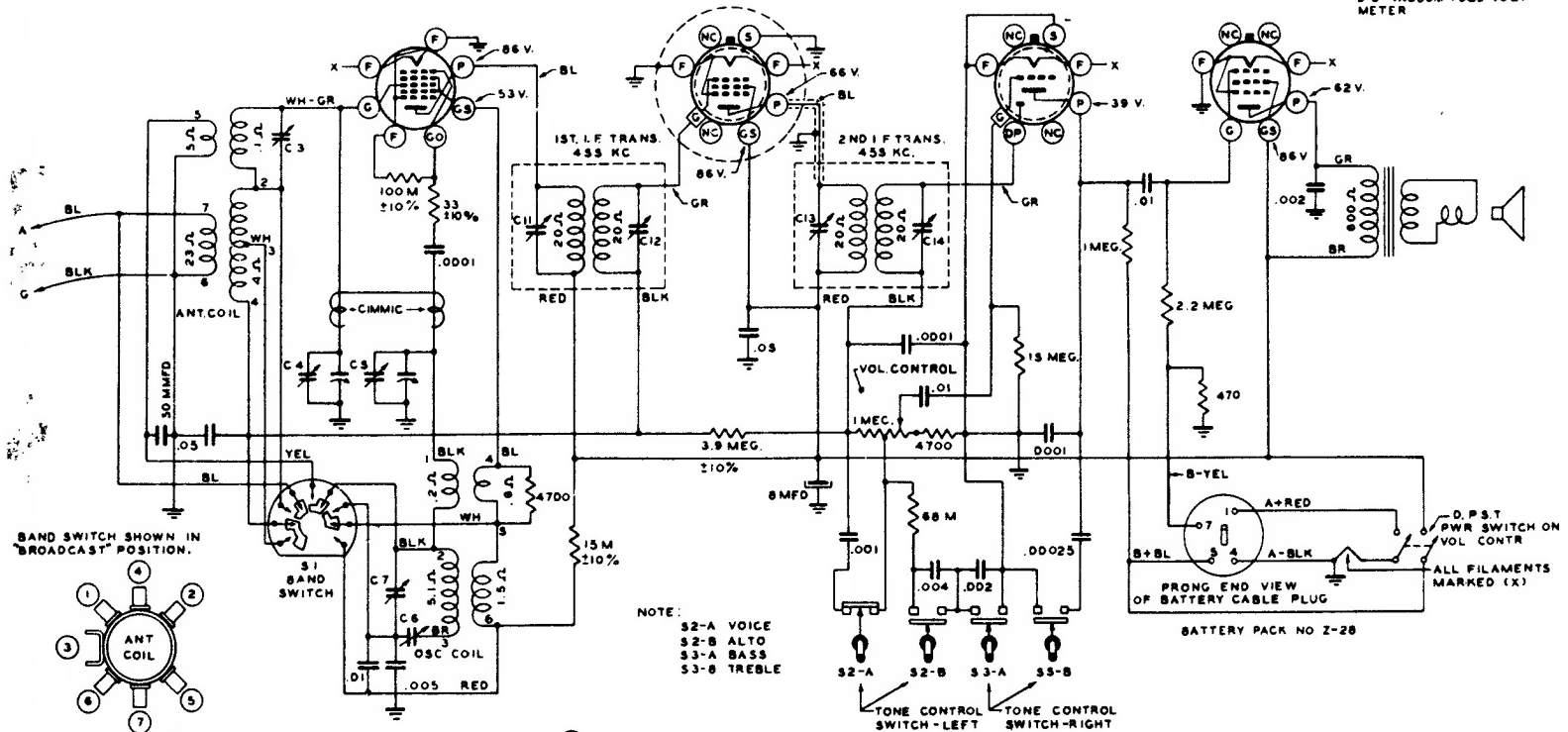

Zenith Radio Corp.

**MODELS 4K040-4K040G
CHASSIS No. 4C54**

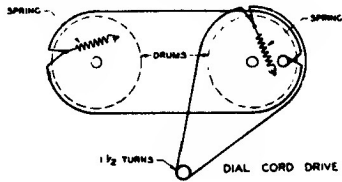

ALIGNMENT PROCEDURE

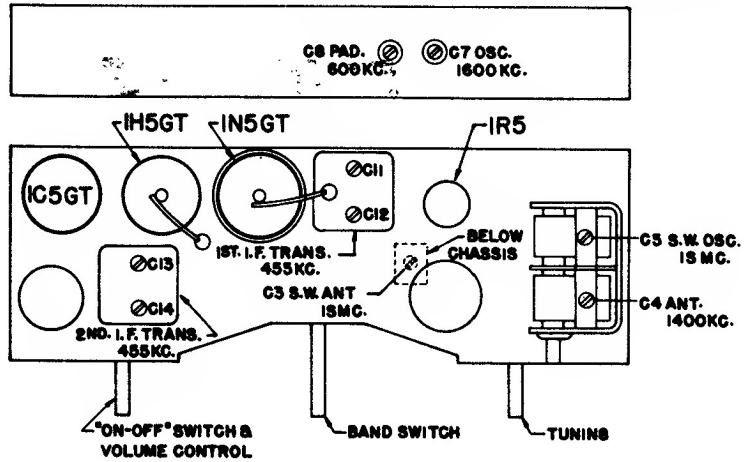

| OPERATION | CONNECT OSC. TO | DUMMY ANT. | INPUT SIG. FREQUENCY | BAND | SET DIAL AT | TRIMMERS |
|-----------|-----------------|------------|----------------------|------|----------------------|------------------------|
| 1 | Converter Grid | .5 Mfd. | 455 Kc. | BC | 600 Kc. | C-11, C-12, C-13, C-14 |
| 2 | Ant.-Gnd. | 400 ohms | 18 Mc. | SW | 18 Mc. | C-5 |
| 3 | Ant.-Gnd. | 400 ohms | 400 ohms | SW | Rock Gang 18 Mc. | C-3 |
| 4 | Ant.-Gnd. | 200 Mmf. | 1600 Kc. | BC | 1600 Kc. | C-7 |
| 5 | Ant.-Gnd. | 200 Mmf. | 1400 Kc. | BC | 1400 Kc. | C-4 |
| 6 | Ant.-Gnd. | 200 Mmf. | 600 Kc. | BC | Rock Gang 600 Kc. | C-8 |

Zenith Radio Corp. Changes between Chassis 11C21 and Chassis 11C21Z shown in circuit diagrams below.

