

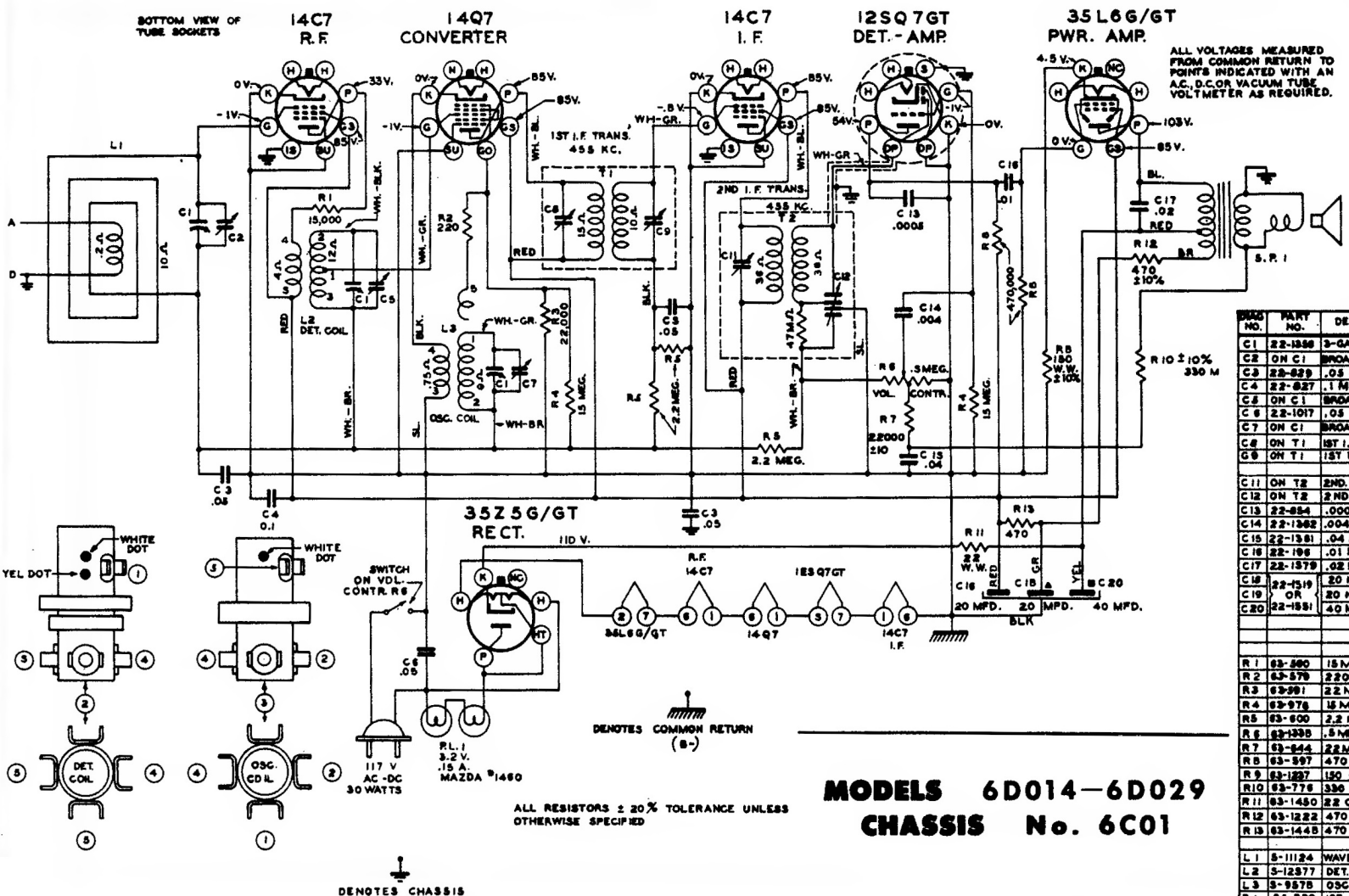

BOTTOM VIEW OF TUBE SOCKETS

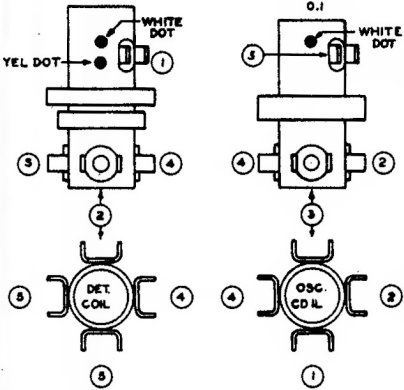

ALL VOLTAGES MEASURED FROM COMMON RETURN TO POINTS INDICATED WITH AN A.C. D.C. OR VACUUM TUBE VOLTMETER AS REQUIRED.



117 V AC-DC 30 WATTS

ALL RESISTORS ± 20% TOLERANCE UNLESS OTHERWISE SPECIFIED

⏏ DENOTES COMMON RETURN (-)

MODELS 6D014-6D029 CHASSIS No. 6C01

Zenith Radio Corp.

QTY	PART NO.	DESCRIPTION
C1	22-1836	3-GANG VARIABLE
C2	ON C1	BROADCAST ANT. TRIM.
C3	22-829	.05 MFD. 200 V.
C4	22-827	.1 MFD. 200 V.
C5	ON C1	BROADCAST DET. TRIM.
C6	22-1017	.05 MFD. 200 V.
C7	ON C1	BROADCAST OSC. TRIM.
C8	ON T1	1ST I.F. TRANS. PRIM. TRIM.
C9	ON T1	1ST I.F. " SEC. "
C11	ON T2	2ND I.F. TRANS. PRIM. TRIM.
C12	ON T2	2ND I.F. " SEC. "
C13	22-854	.0005 MFD. 800 V.
C14	22-1362	.004 MFD. 800 V.
C15	22-1381	.04 MFD. 400 V.
C18	22-196	.01 MFD. 800 V.
C17	22-1379	.02 MFD. 400 V.
C19	22-1519	20 MFD. ELECTRO 150 V.
C19	OR	20 MFD. ELECTRO 150 V.
C20	22-1891	40 MFD. " "
R1	83-390	18 M OHM 1/2 W.
R2	63-578	220 OHM 1/2 W.
R3	93-297	22 M OHM 1/2 W.
R4	93-978	18 MEG OHM 1/2 W.
R5	83-800	2.2 MEG OHM 1/2 W.
R6	83-1335	.5 MEG. VOL. CONTROL
R7	83-844	22 M OHM 1/2 W.
R8	63-597	470 M OHM 1/2 W.
R9	63-1227	150 OHM WIREW. 0.5 W.
R10	83-776	330 M 1/2 W.
R11	83-1450	22 OHM W. W. 1 W.
R12	63-1222	470 OHM 1 W.
R13	63-1445	470 OHM 1 W.
L1	5-11124	WAVEMAGNET ASBY.
L2	5-12877	DET. COIL
L3	5-9578	OSC. COIL
T1	95-860	1ST I.F. TRANS.
T2	95-988	2ND I.F.
PL1	100-90	PILOTLIGHT 3.2V. 15A.
SP1	49-548	5" P. M. SPEAKER

I.F. FREQUENCY 455 KC.
TUNING RANGE 535-1620 KC.

ALIGNMENT PROCEDURE

CONNECT OSCILLATOR TO	DUMMY ANTENNA	INPUT SIG. FREQUENCY	SET DIAL AT	TRIMMERS	PURPOSE
Converter Grid	.5 Mfd.	455 Kc.	600 Kc.	C-8, C-9, C-11, C-12	Align I. F.
{ One Turn Loop Coupled Loosely to Wave Magnet }	--	1600 Kc.	1600 Kc.	C-7	Set Oscillator to Dial Scale.
	--	1400 Kc.	1400 Kc.	C-5	Align detector
	--	1400 Kc.	1400 Kc.	C-2	Align antenna stage

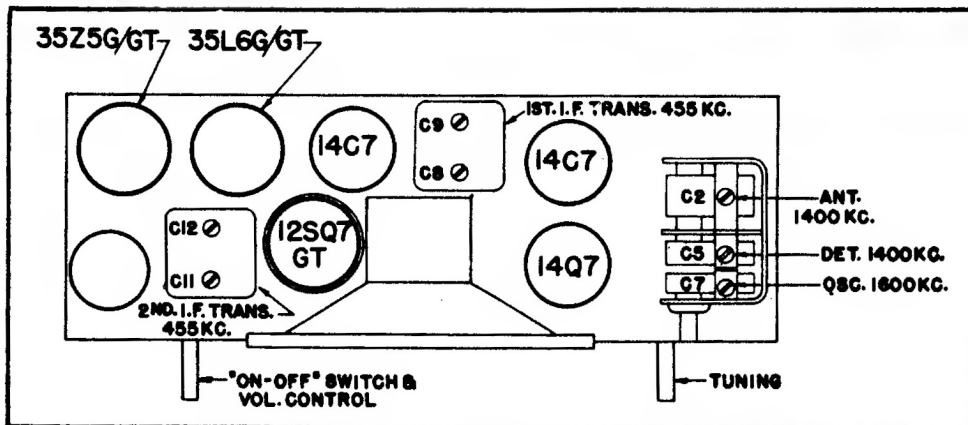

TUBE AND TRIMMER LOCATION

Chassis 6C01 features a high gain tuned R.F. circuit ahead of a conventional superheterodyne circuit, with feedback in the audio circuit, and a new filter circuit to reduce hum to a minimum.

Part of the audio voltage from the voice coil is fed back to the first audio grid (12SQ7) in phase through resistor R10 and R7 to a tap on the volume control R6. Capacitor C15 bypasses highs to ground. One side of the output transformer secondary is grounded. The side grounded determines the phase relationship of the feedback voltage, therefore, when replacing the output transformer be certain the proper end of the secondary is grounded or degeneration will result. The overall result of this arrangement is to boost the bass tones.

The filter circuits of chassis 6C01 incorporate new features that should be well understood by the service man. An examination of the schematic drawing will show the output transformer tapped slightly off center. This tap is the B+ connection from filter resistor R11 and capacitor C20 off the cathode of the rectifier 35Z5 to the 35L6 plate. The lower connection of the output transformer feeds B+ to the rest of the tubes in the receiver. Current flowing through the upper windings of the output transformer to the 35L6 produces a magnetic field which is 180° out of phase with the magnetic field produced by current flowing in the opposite direction through the output transformer to the rest of the receiver, therefore, most of the AC hum is cancelled. Further reduction of hum is accomplished by filtering through resistors R12 and R13 and capacitors C18 and C19.

This development in filtering systems allows a higher effective plate voltage on the 35L6 for increased power output.

